

# BOSCH EDC15C3

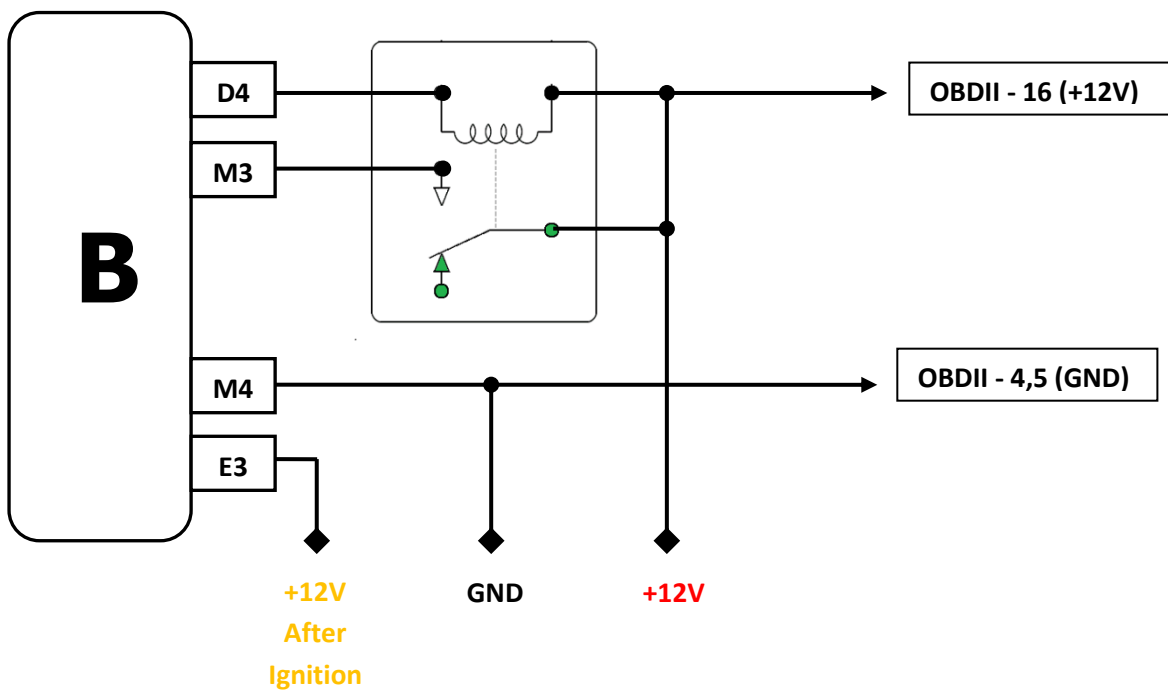

# BOSCH EDC15C13

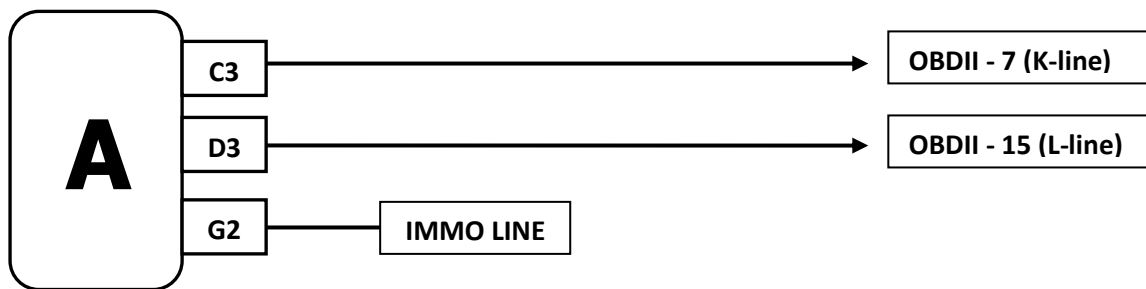
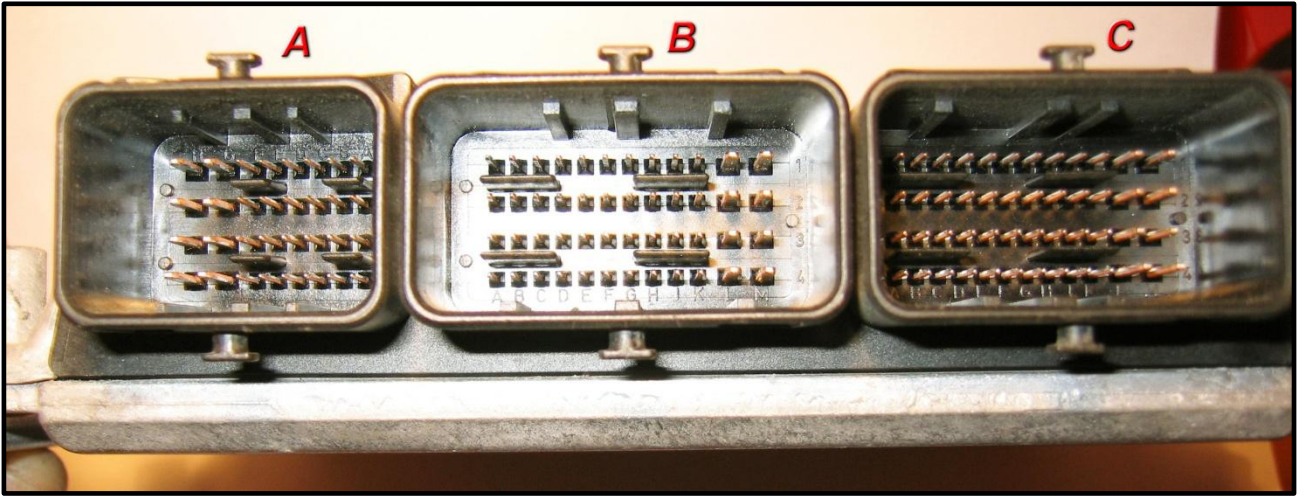
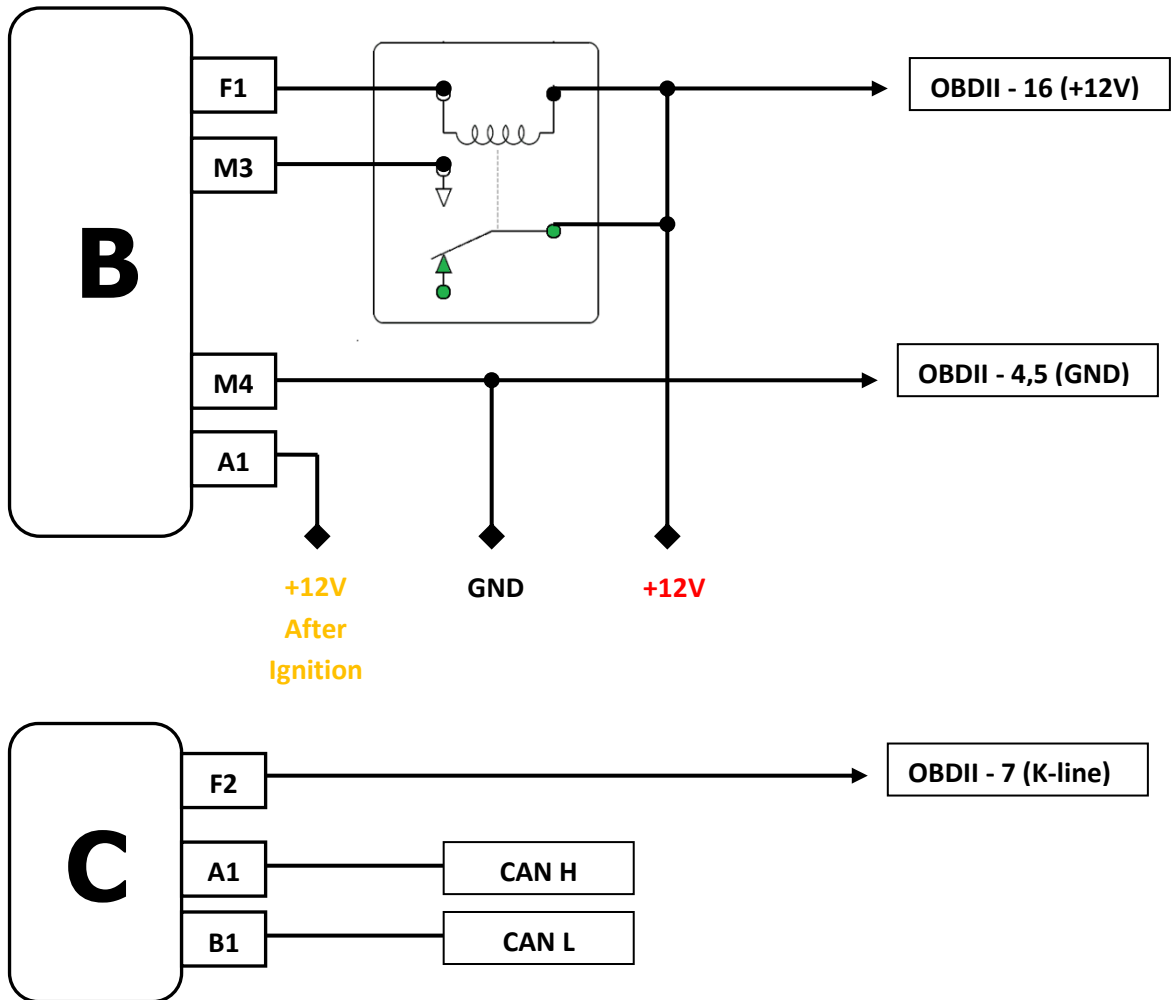

# SAGEM SAFIR/SAFIR2 (MAGNETI MARELLI SFR200) with 35 pin connector

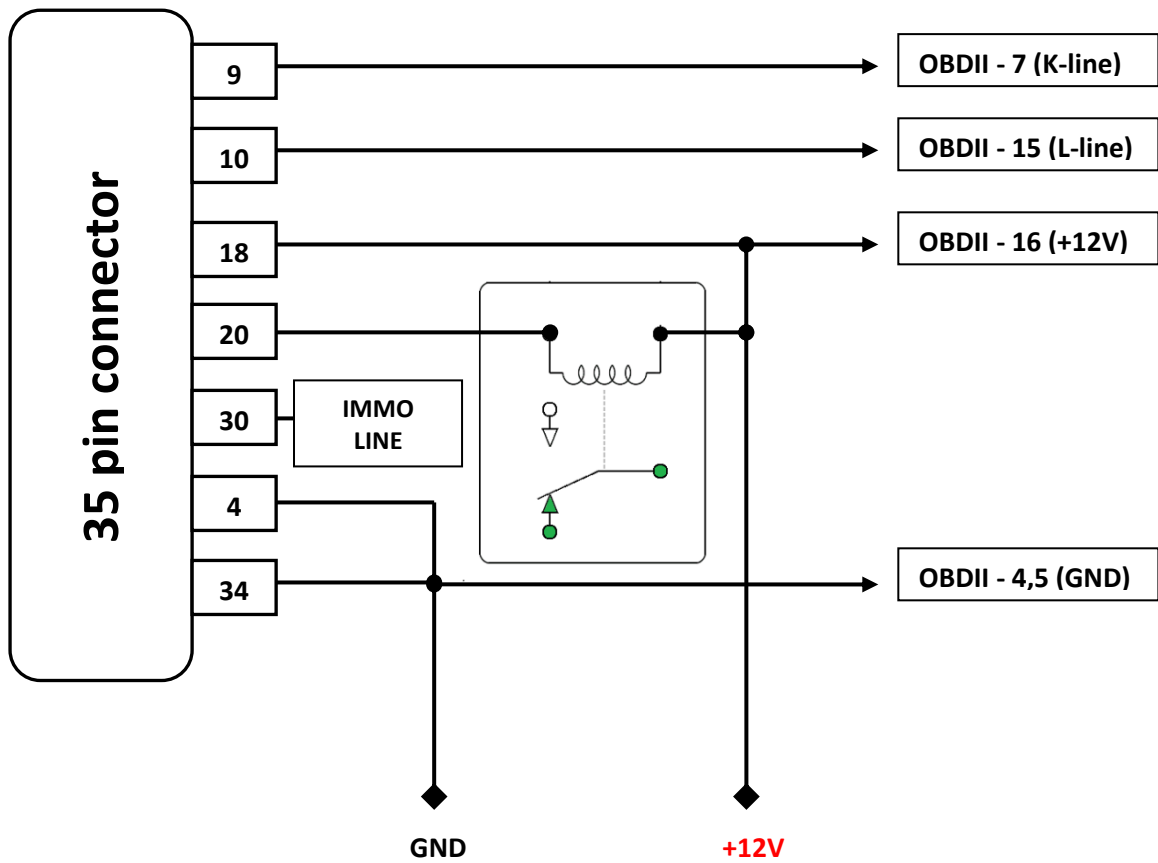
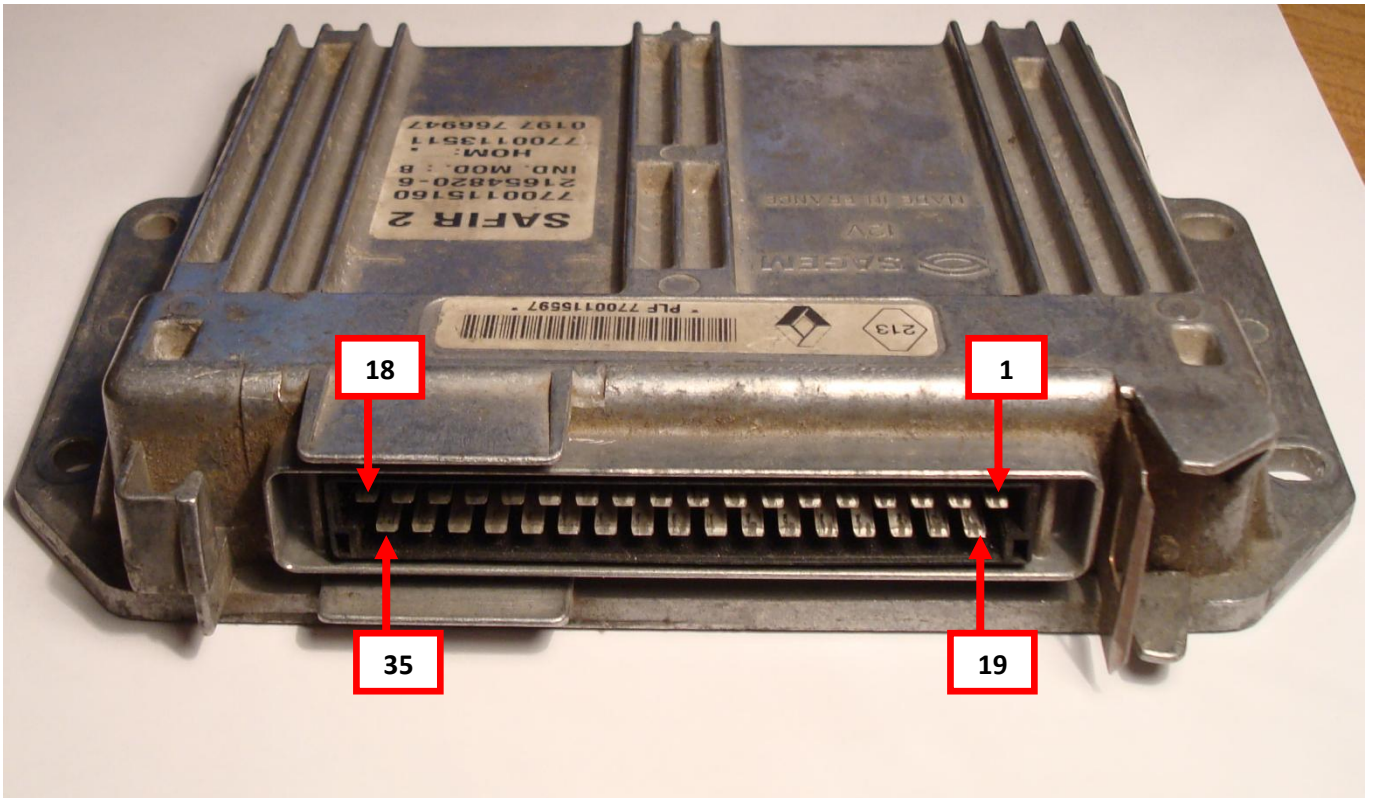

# SAGEM SAFIR / SAFIR2 with 55 pin connector

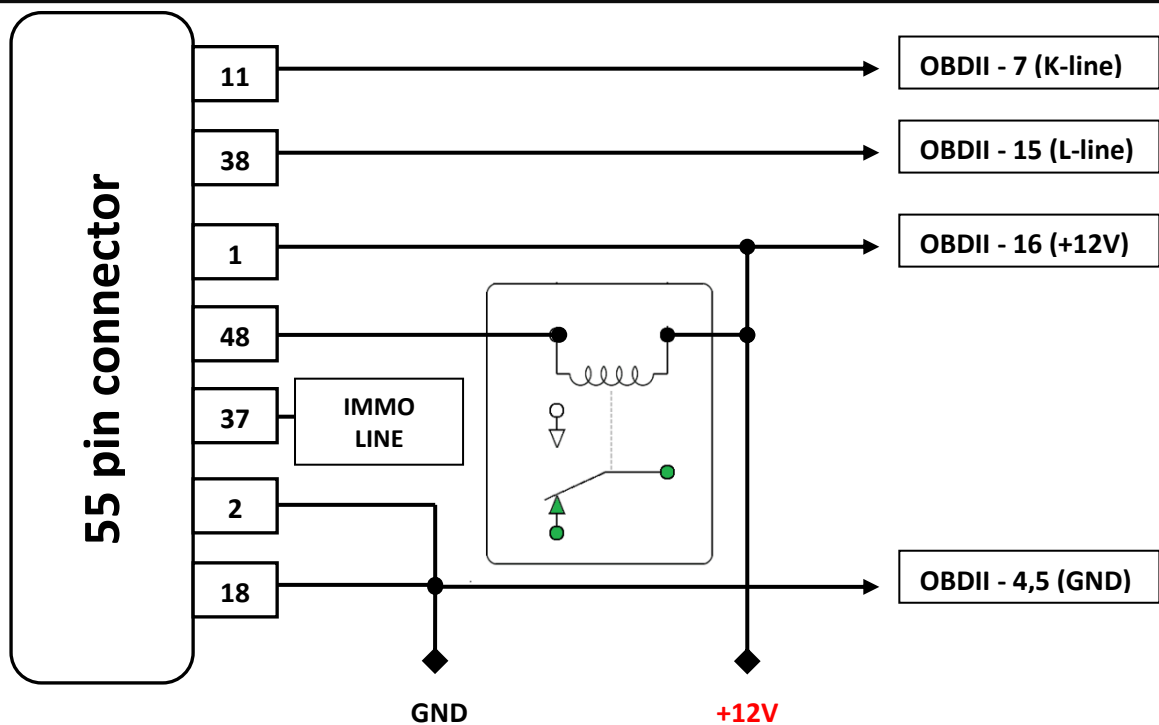
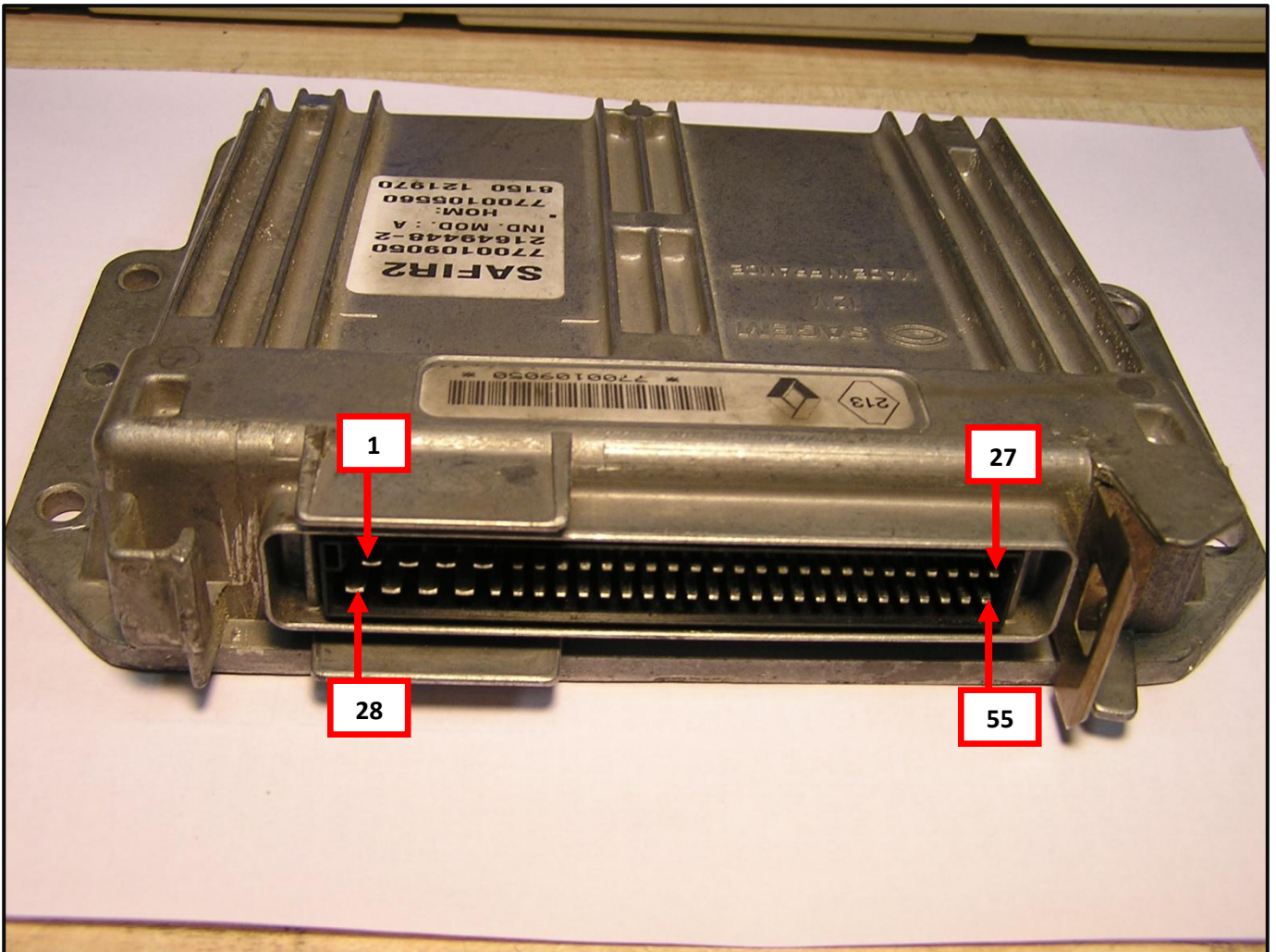

SIEMENS SIRIUS 32/SIRIUS 32N (Up to year 2002. With Immobilizer by WIRE)

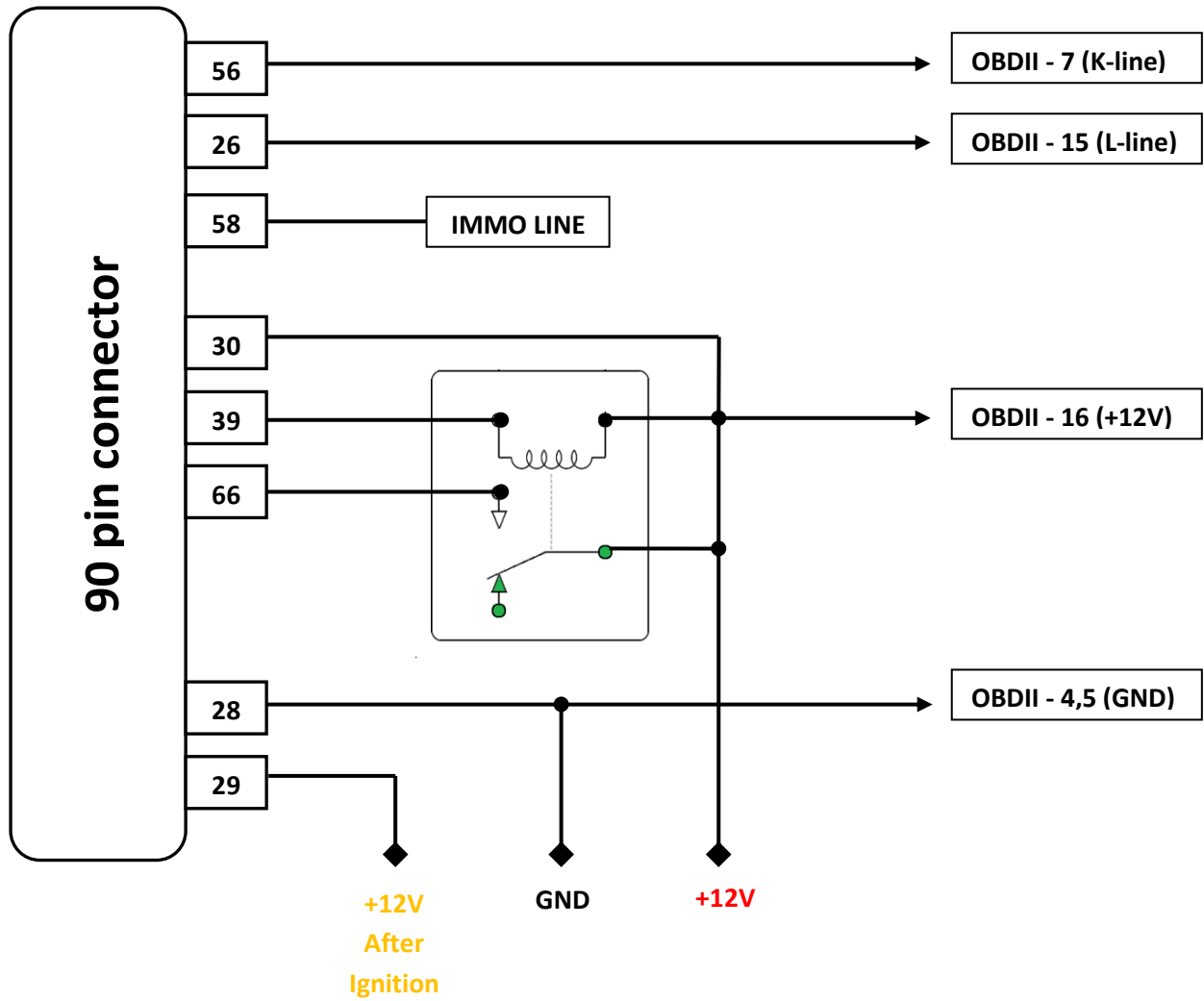

# SIEMENS SIRIUS 34 / EMS3134 (With Immobilizer by CAN)

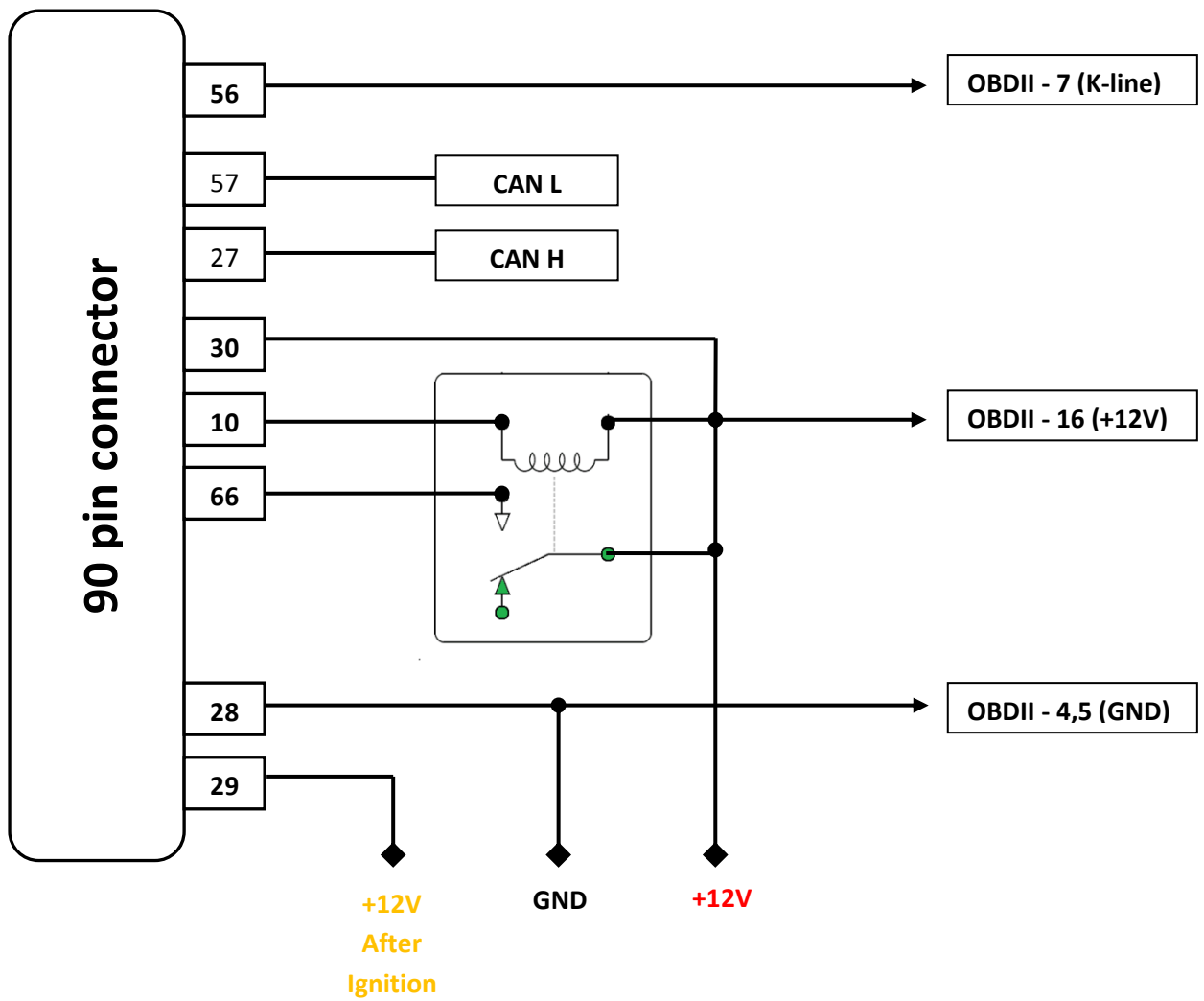

# SIEMENS SIRIUS 34 (With Immobilizer by WIRE)

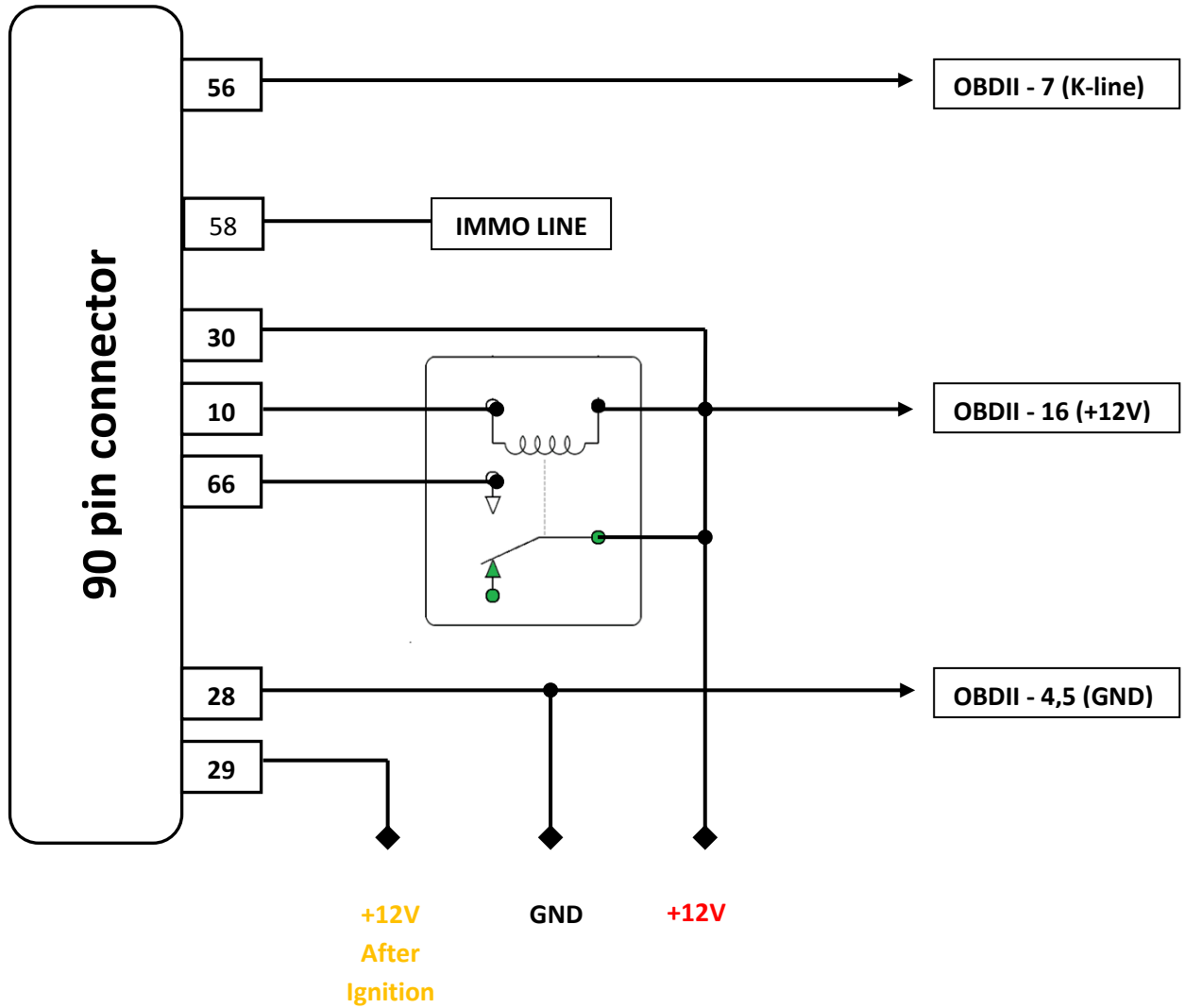

# SIEMENS SIRIUS 35

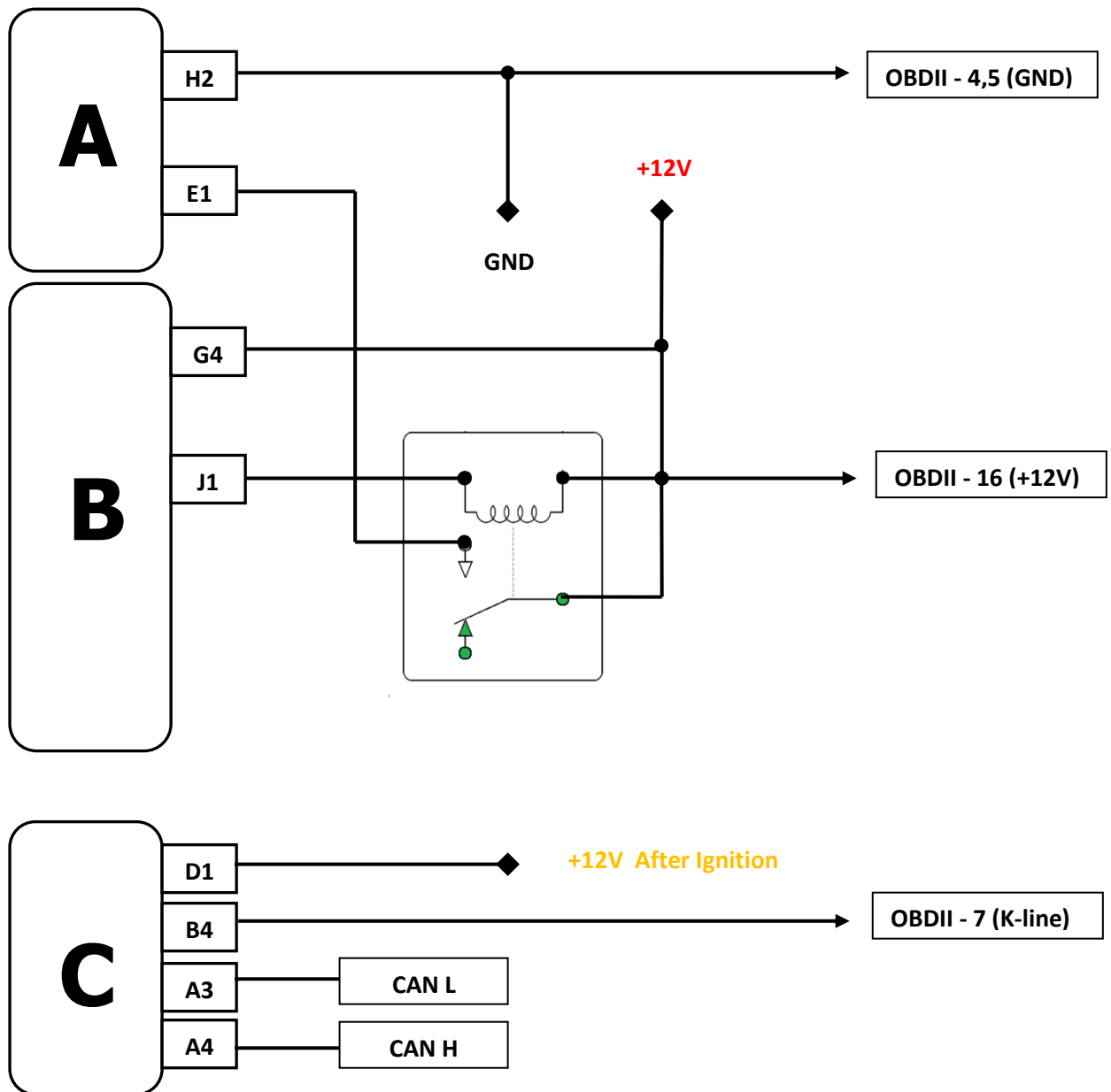
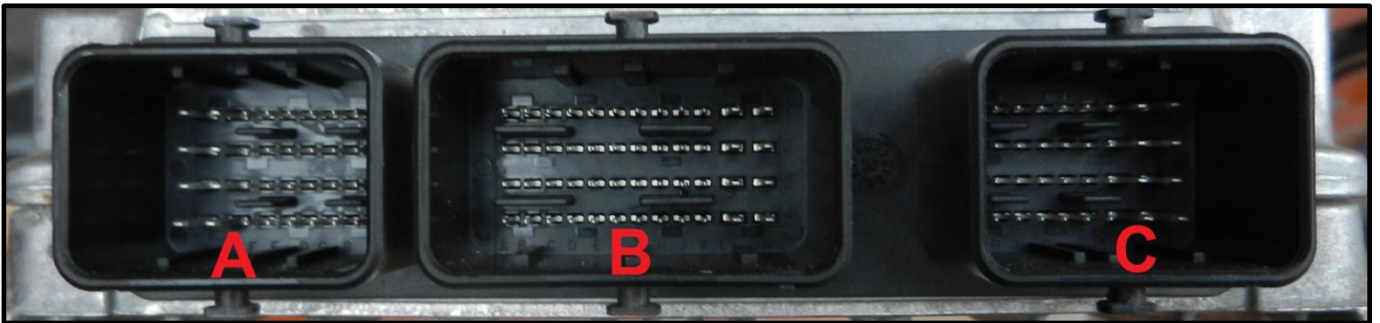



SIEMENS EMS3132 / SIRIUS 32N (From year 2002. With Immobilizer by CAN)

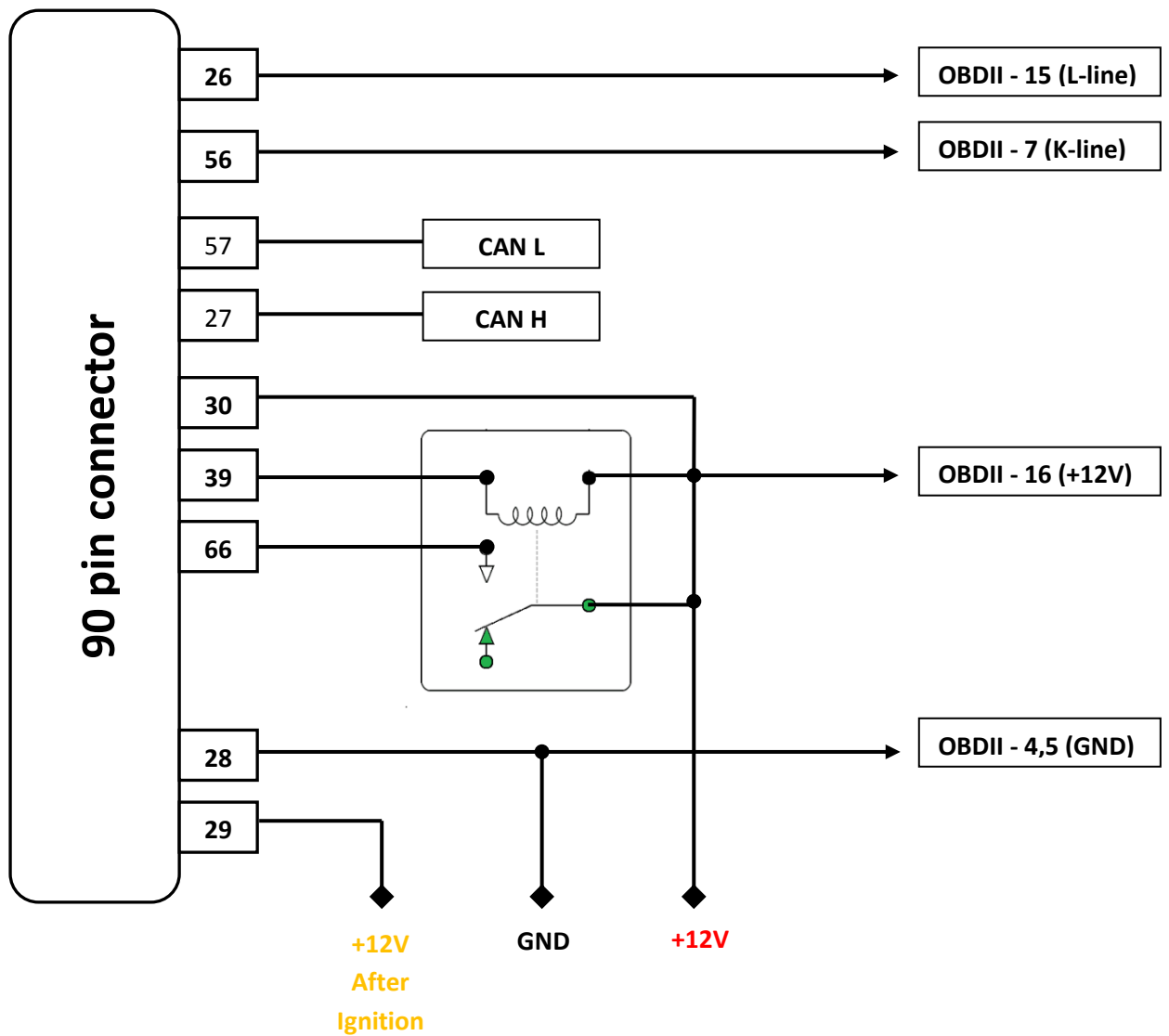

# SIEMENS SID301

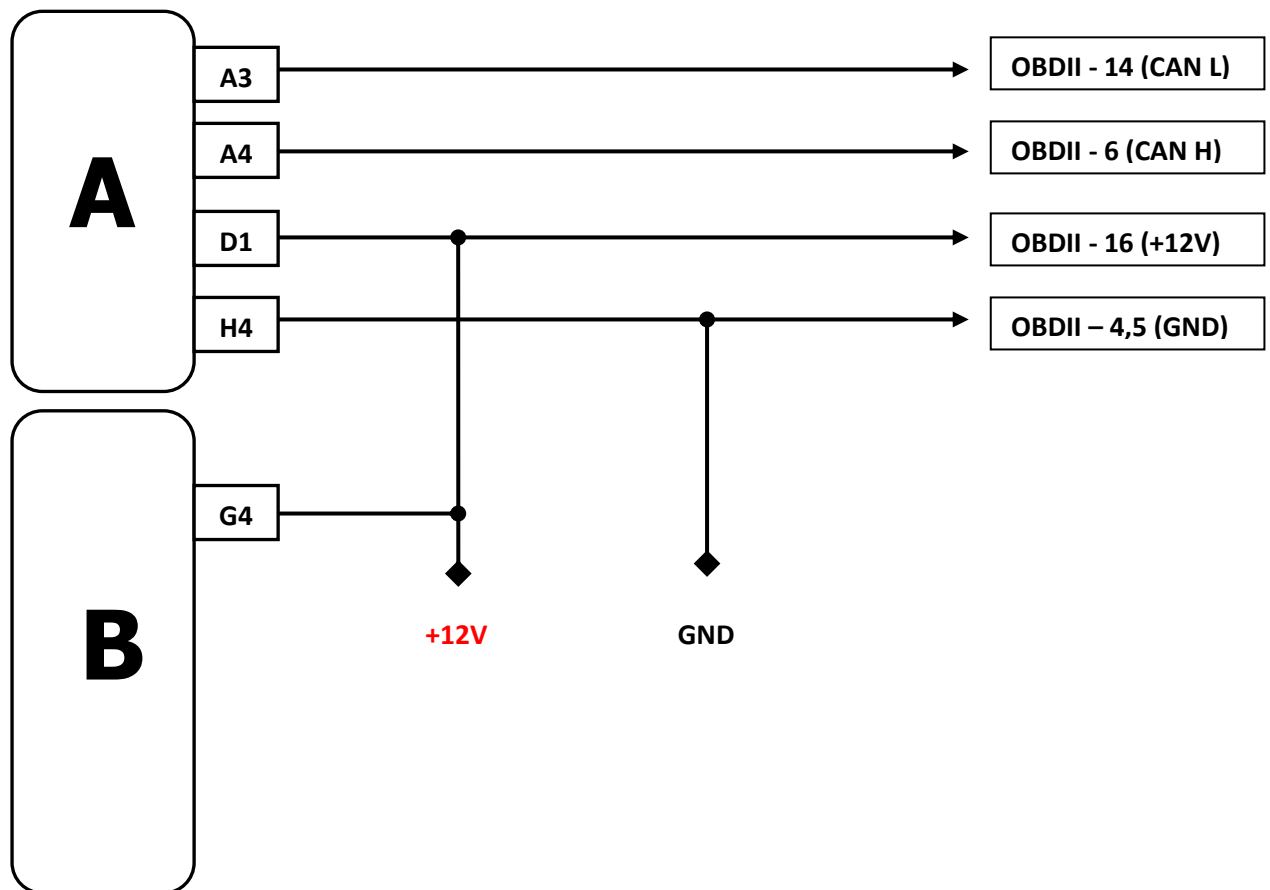
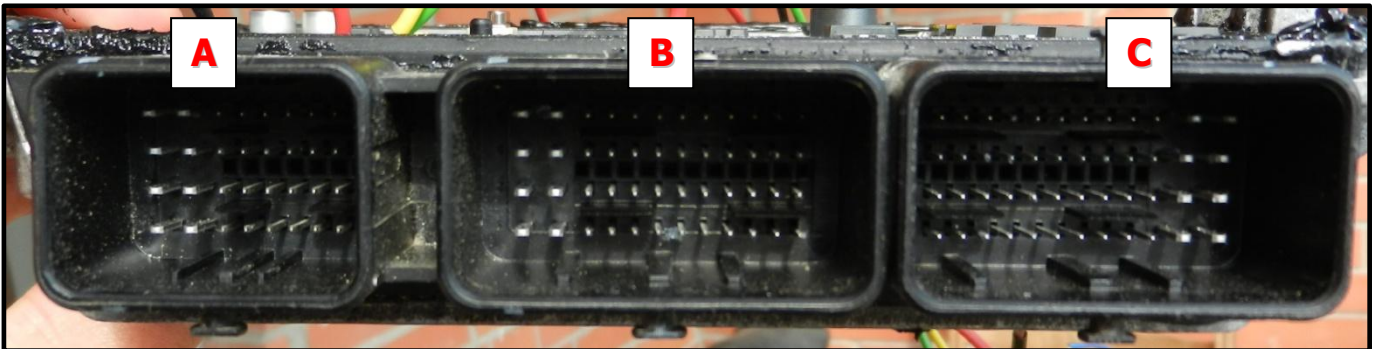

# MAGNETI MARELLI IAW 6R.20 / IAW 6R.30

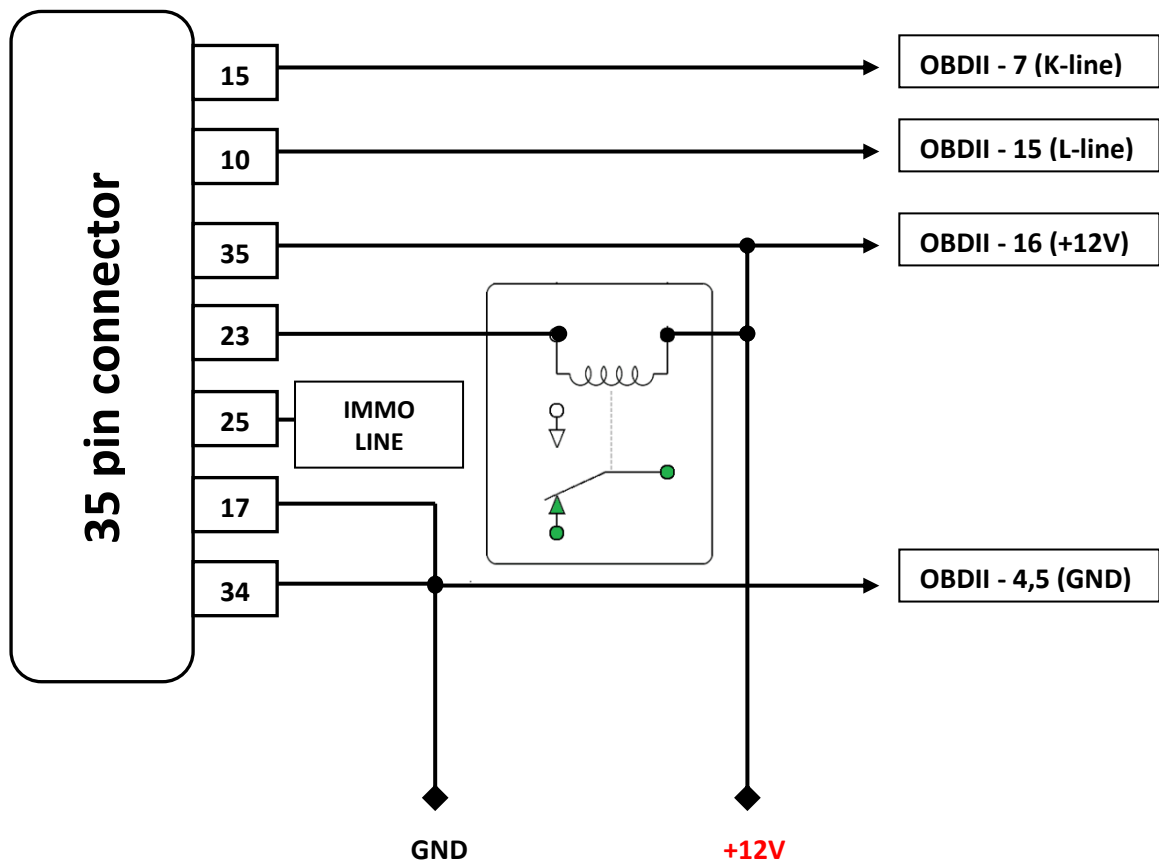
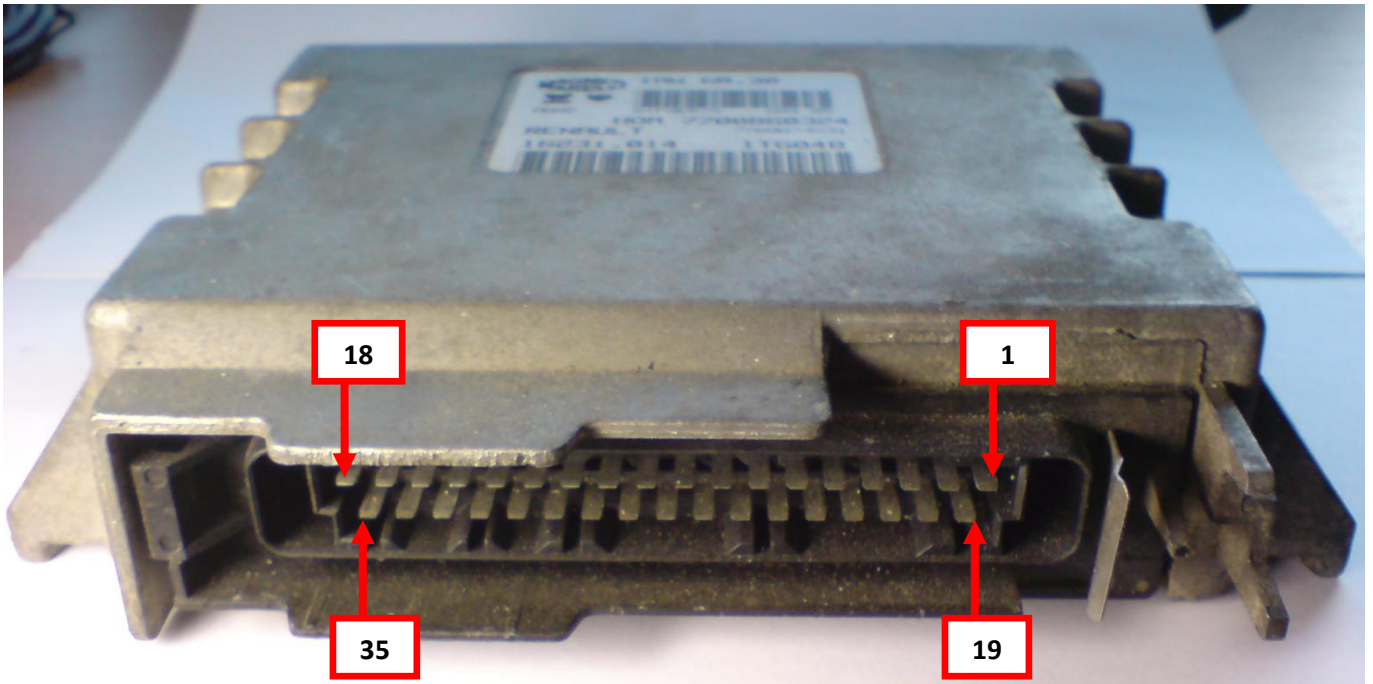

# SPACE III VALEO Interconnection Unit (BII)

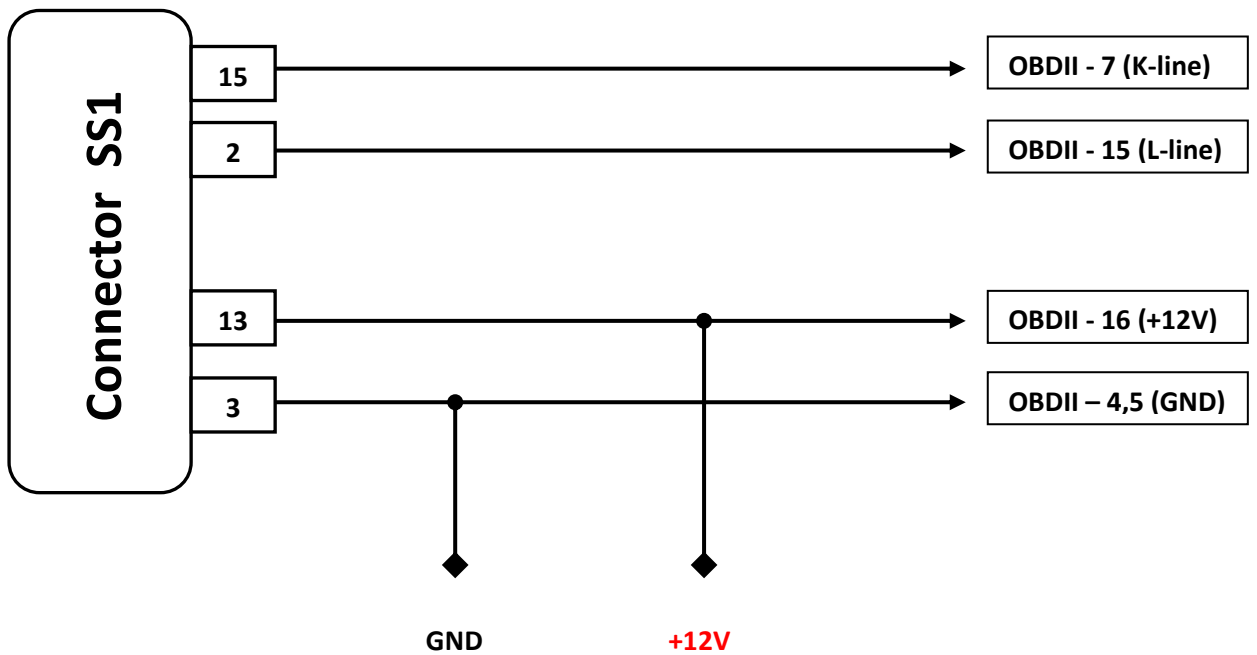
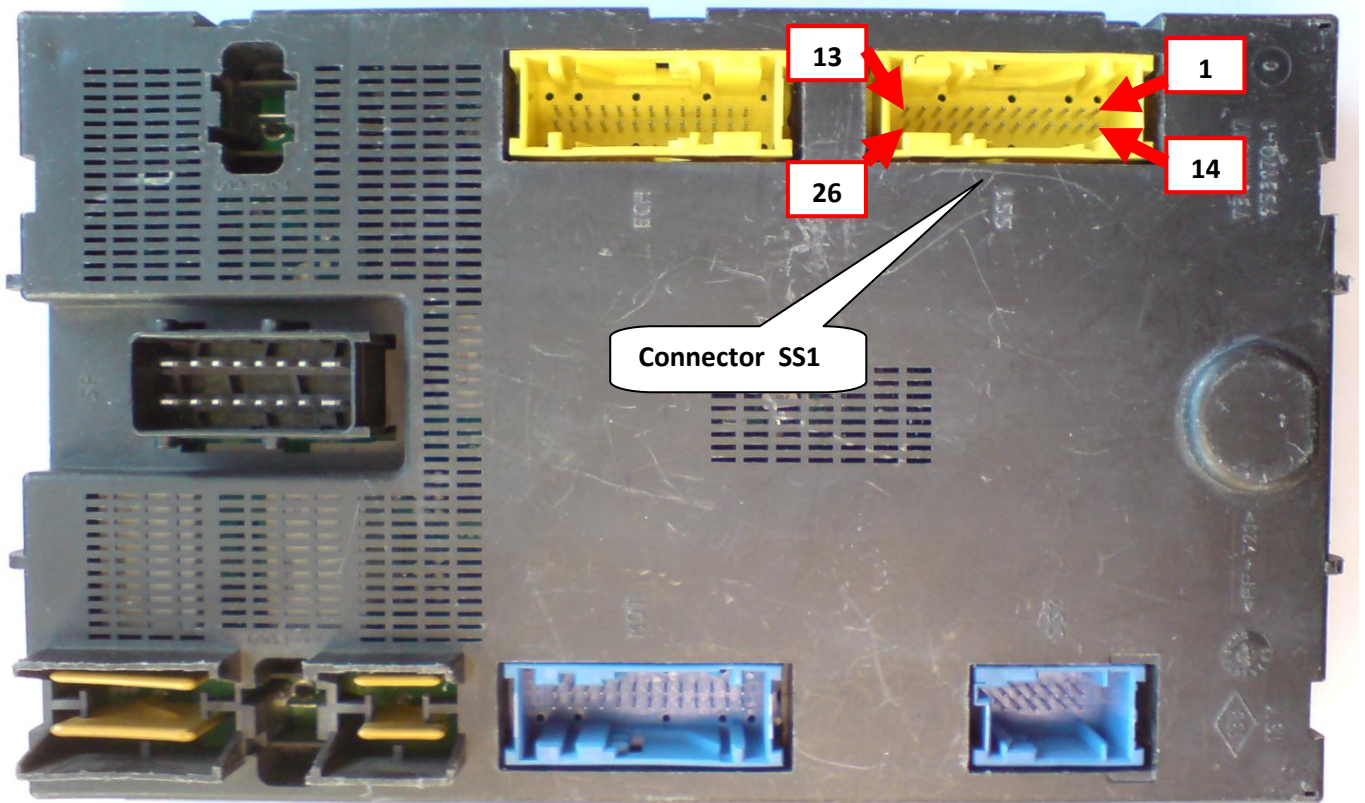

# MEGANE / SCENIC [1998-2002] SIEMENS Interconnection Unit (UCH)

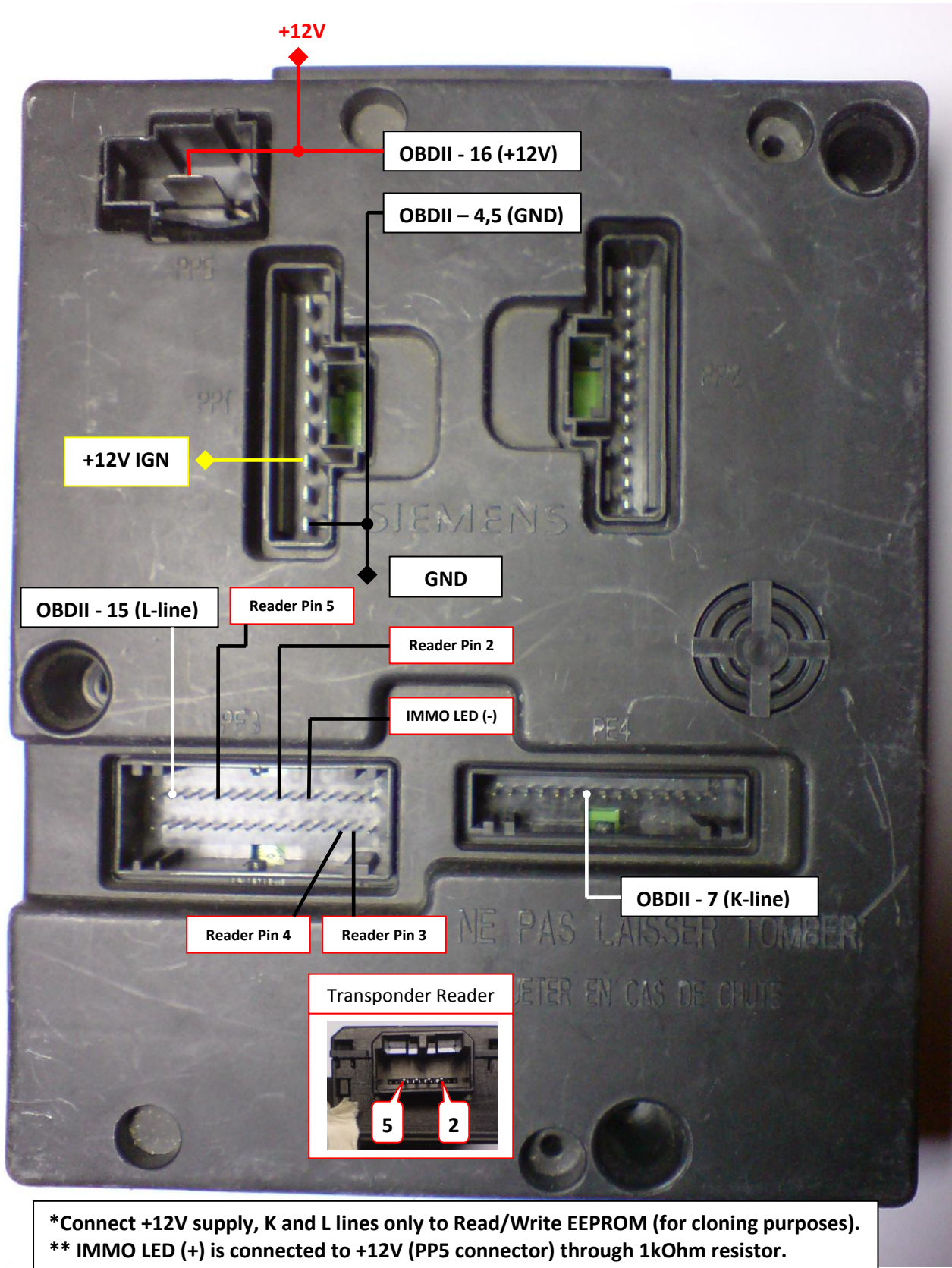

# INSTRUMENT CLUSTER FOR SCENIC II [2004-2008]

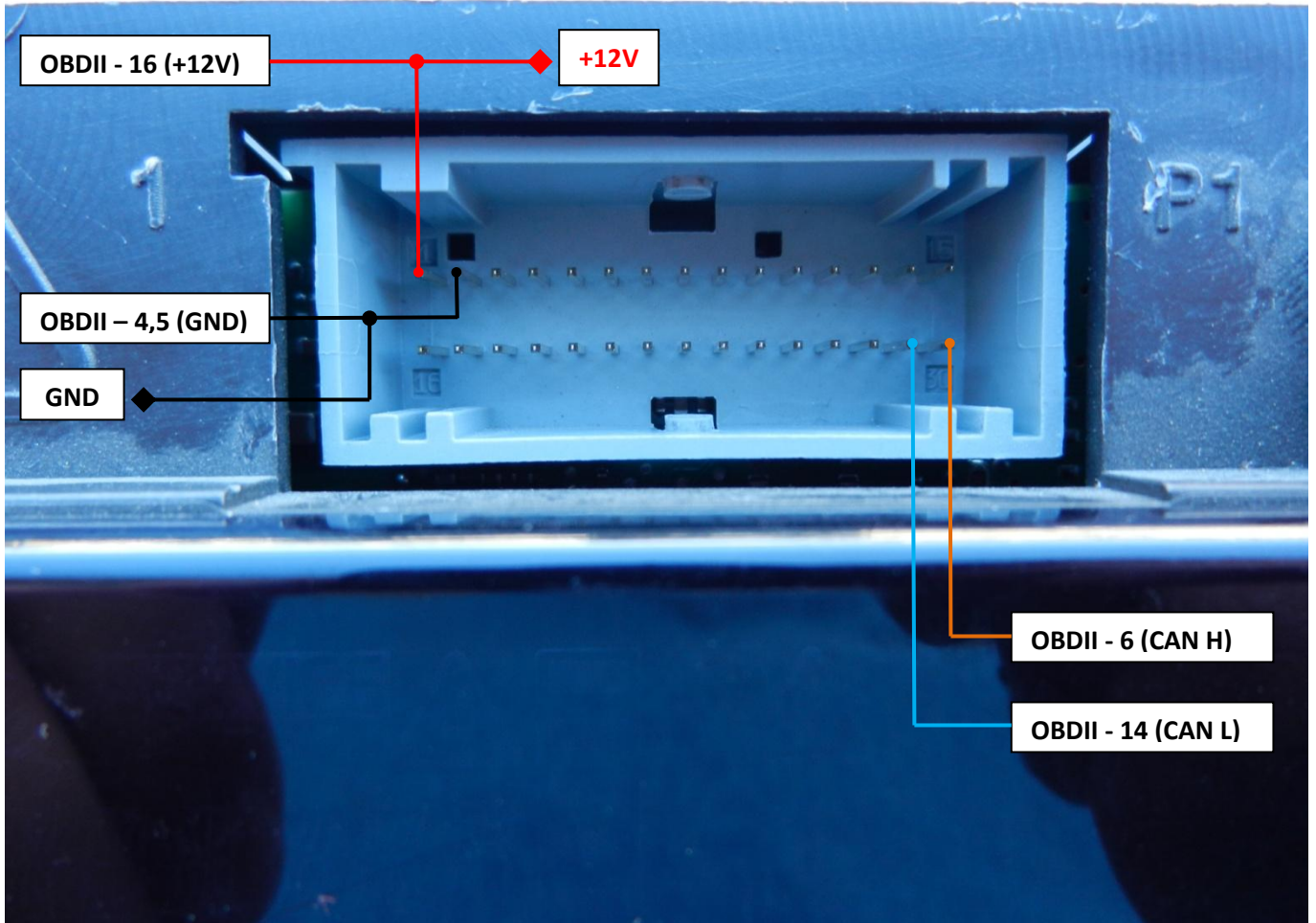

## ELECTRIC POWER ASSISTED STEERING (TRW DAE/PAS) FOR MODUS / CLIO III

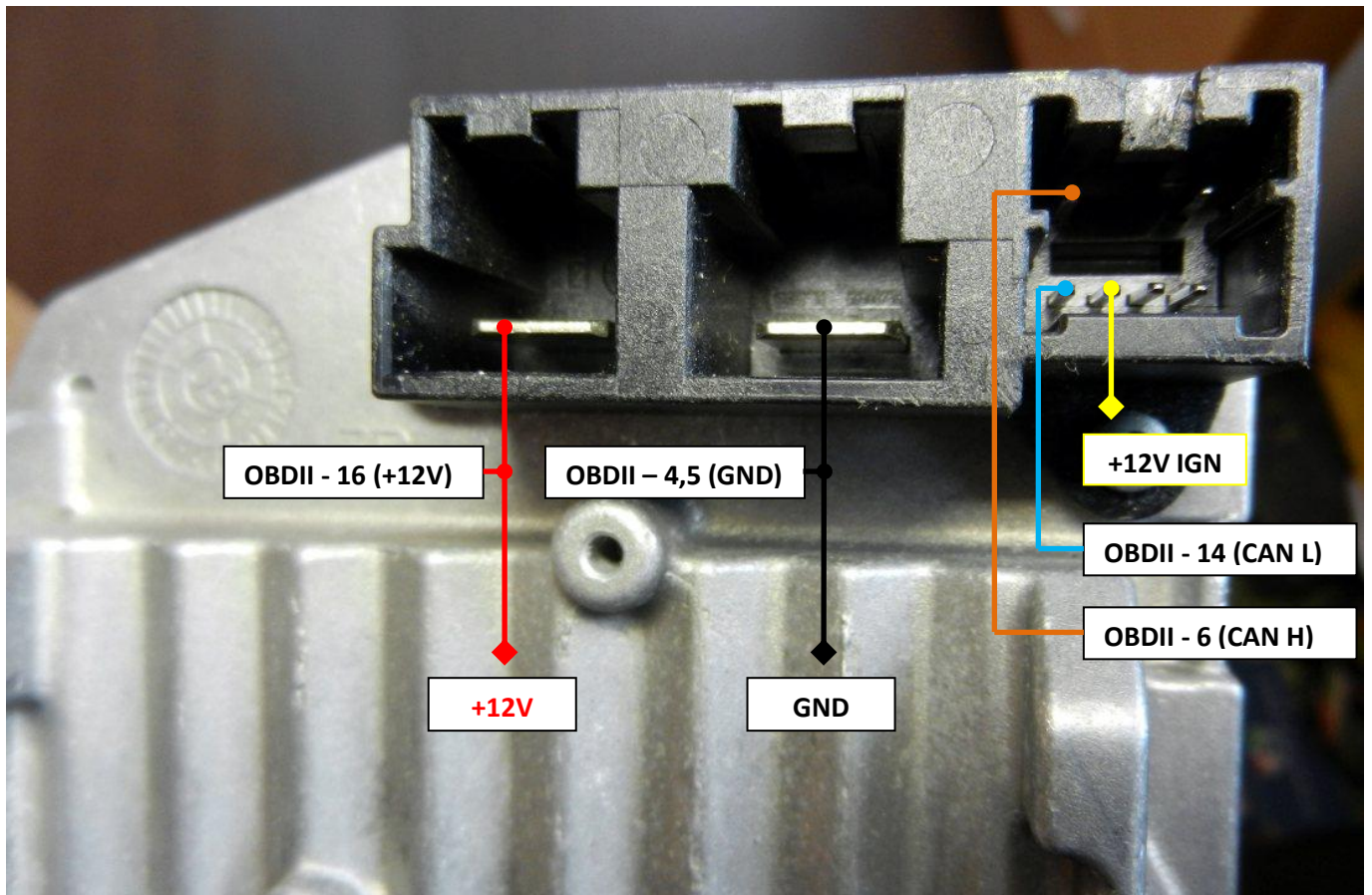

**NOTE:** Connect 120 Ohm resistor between CAN-L and CAN-H lines to diagnose PAS module using CAN CLIP in the “on the bench” connection. There is no need for this resistor when connecting to RENAULT ECU TOOL.