

FORD KA NEC

ENIGMA



USE CABLE **C13** ALWAYS CONNECTED TO **A1** ADAPTER. OPEN BACK SIDE FROM DASH, WHEN WE CAN SEE MAIN BOARD, CONNECT OR SOLDER CABLE LEADS ACCORDING TO NUMBER AS SHOWN OF BELOW PHOTOS:

VERSION 1:

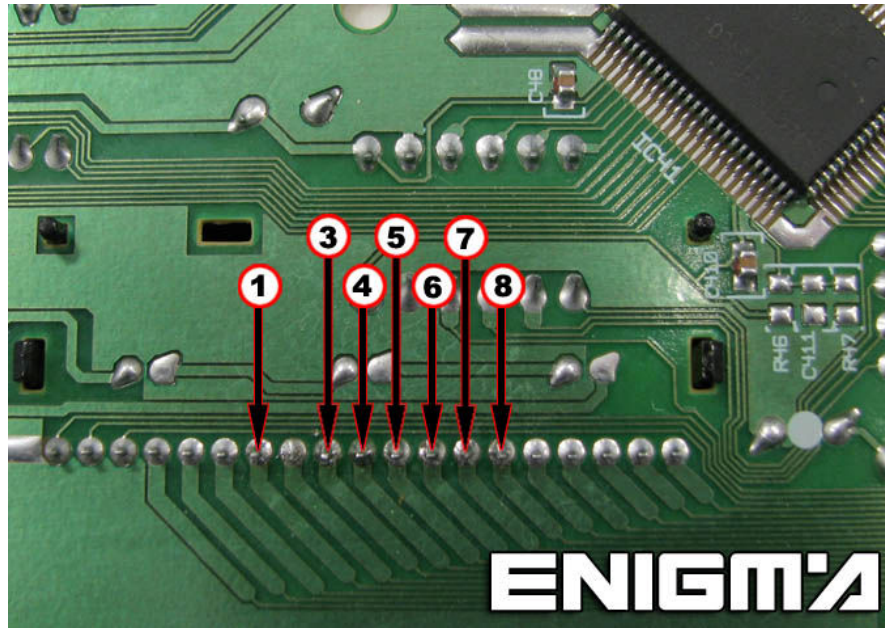

LIFT UP PINS 9-10-11-12

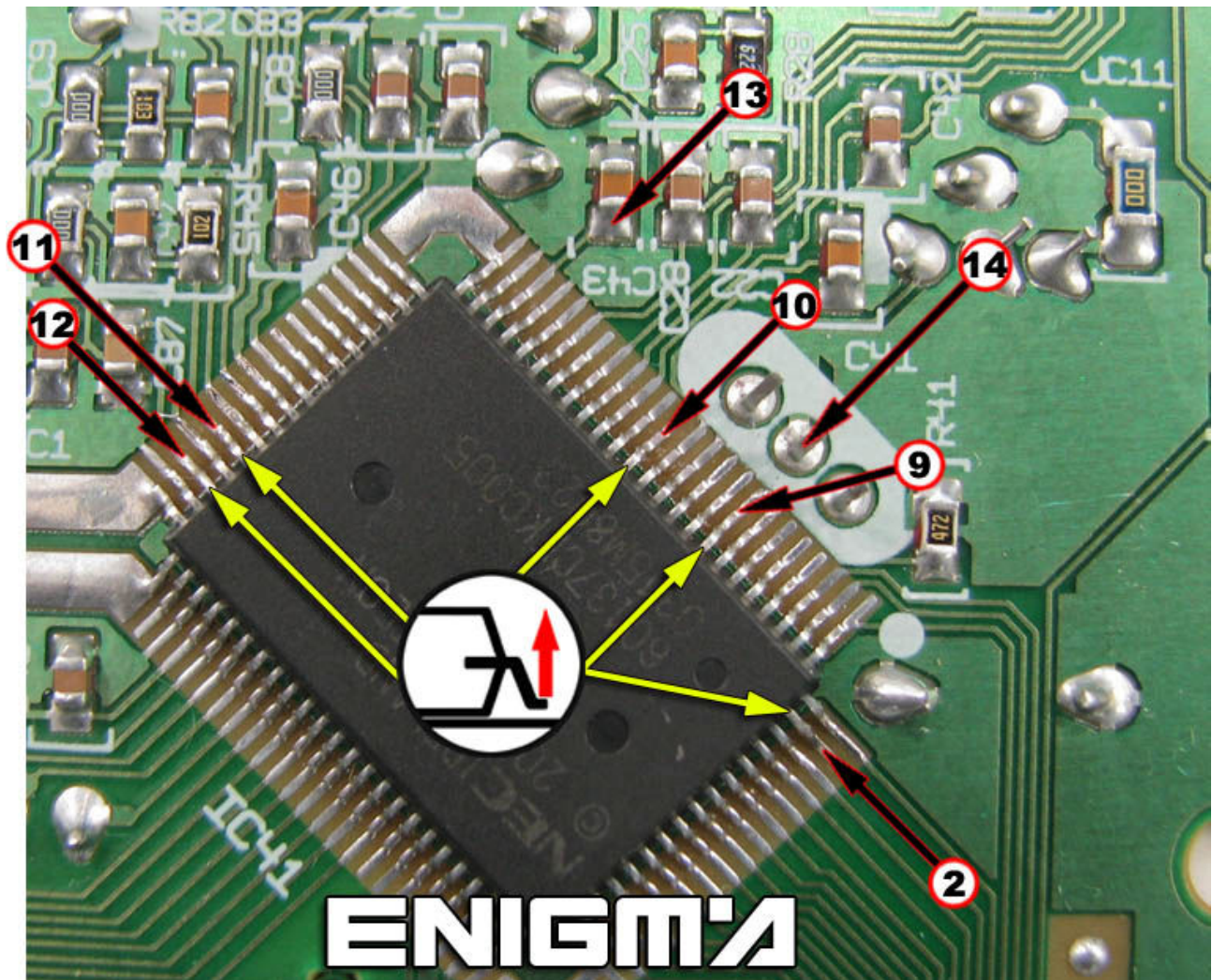

VERSION 2:

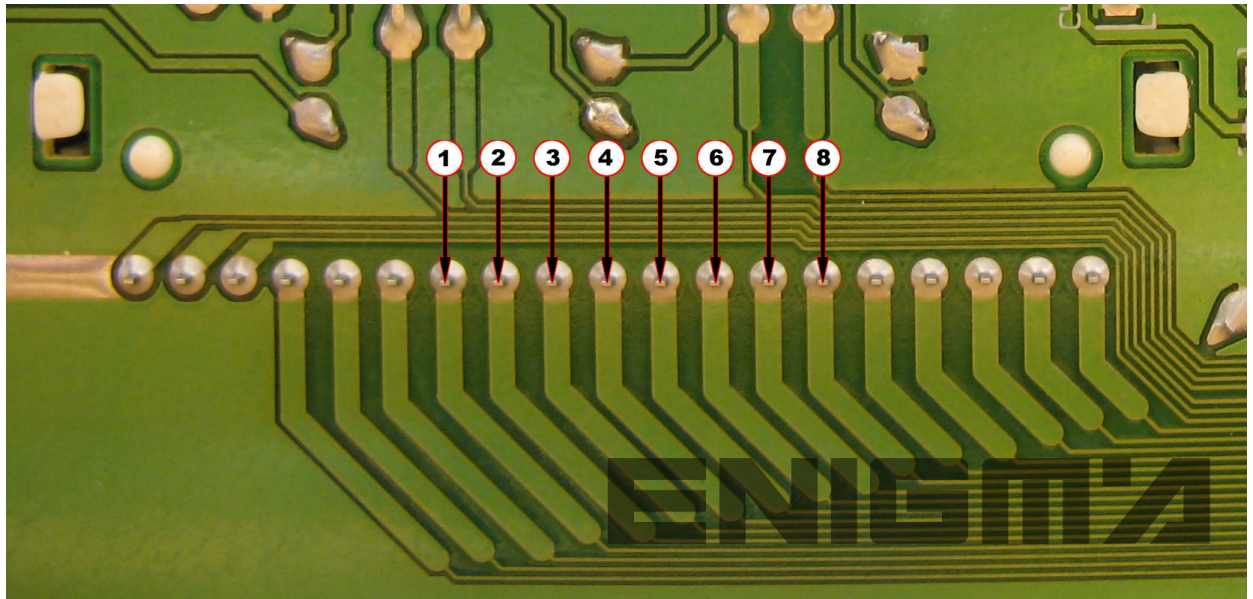

LIFT UP PINS 9-10-11-12

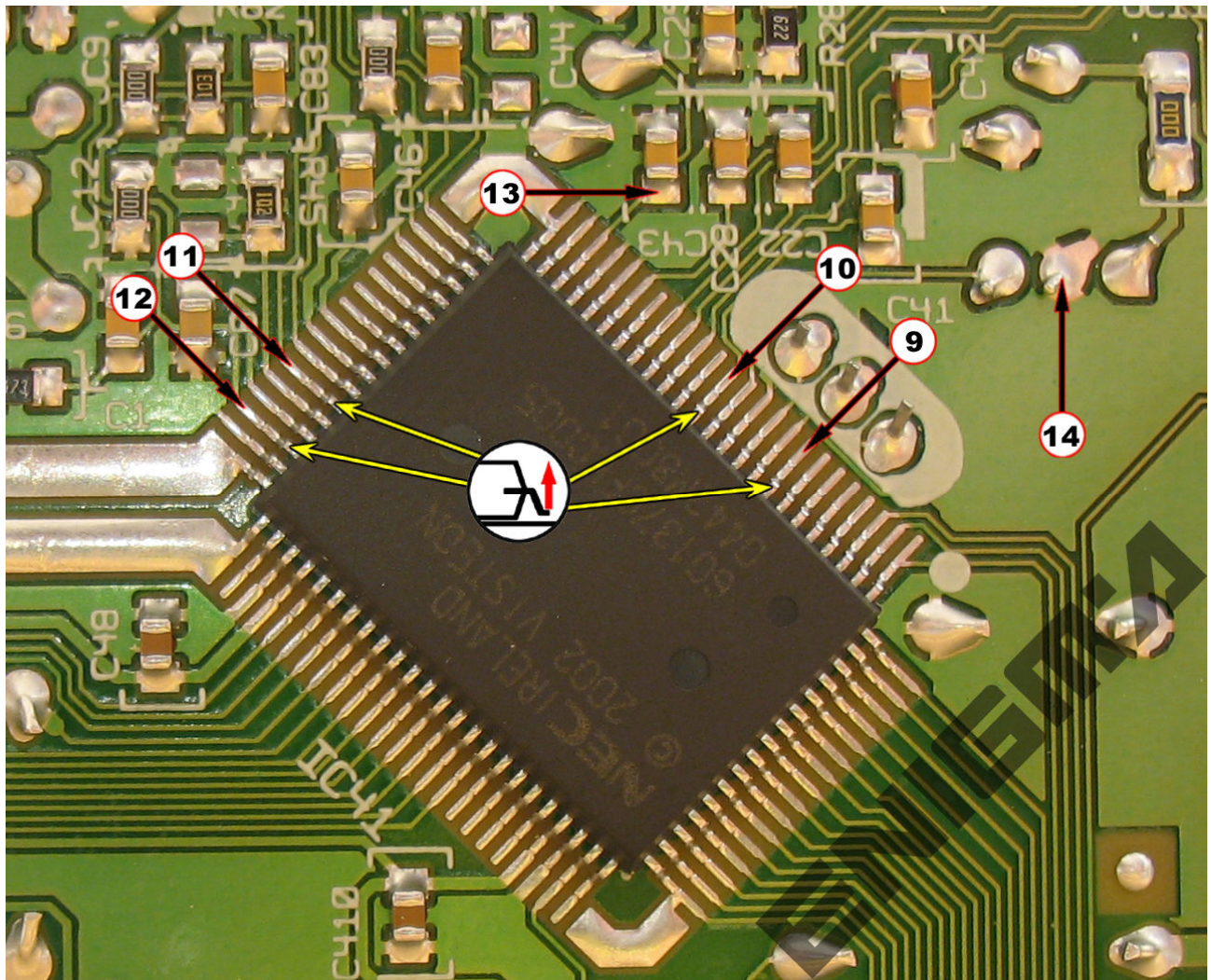

VERSION 3:

LIFT UP PINS 10-12

