

MST-12000

1.Product introduction:



Packing list:

The MST-12000 sensor signal simulator	1set
The data line	60 pieces
Power line	1 piece
The USB data line	1 piece
Data disc	1piece

2.The basic function of the instrument:

The all cars crankshaft signal simulation expert:

①Twelve way set arbitrary waveform output, can produce all of today's car engine crankshaft, camshaft signal (Hall, magnetolectric, photoelectric signal), waveform data will be preserved by computer for long term.

②All magnetolectric crankshaft signal will be isolated by transformer, ensure no interference between signals.

③The whole series of car sensor signal simulation expert:

The rotational speed signal, the speed signal (Hall, magnetolectric, photoelectric signal), the ABS wheel speed signal, oxygen sensor signal, throttle valve, the accelerator pedal signal, air flow meter, the intake pressure sensor (analog, digital), knock sensor etc signals simulation.

④The All cars actuator drive experts:

Tachometer, odometer, blower control module, ignition module, frequency and pulse width control solenoid valve, car audio power amplifier.

⑤The All cars actuator simulation expert

Diesel common rail injector, rail pressure control valve, ignition coil, injector, idle stepper motor, ultrasonic generator,etc actuator simulation.

⑥Detailed Fuctions:

The user can set crankshaft of different types according to different independent engine control system

- The signal output (applicable to all car models of computer driven)
- automatic transmission input/output shaft signal simulation
- Set to write into the waveform data directly
- Engine revolving speed signal output
- The speed signal output (hall signals, magnetolectric)
- Three or four channel ABS wheel speed signal output
- Computer board working current test
- EGR solenoid valve simulation
- CANP Canister Purge solenoid simulation

- Tachometer simulation and drive
- Blower control module driver
- Auxilliary air regulator simulation
- Stepping motor simulation(Four/Six line)
- Fuel injector simulation
- Ignition coil simulation
- The ignition module simulation
- Reversing radar (ultrasonic) probe drive
- The shift valve of automatic transmission simulation
- Diesel injector simulation
- Rail pressure regulator simulation
- Shift quality valve simulation
- Oil pressure regulating valve simulation
- water temperature, air temperature, outdoor temperature and evaporation temperature sensor signal simulation
- Oxygen sensor signal simulation (manual)
- The accelerator pedal double channel signal simulation
- Throttle signal simulation
- CANP Canister purge solenoid simulation
- Air flow meter, manifold Absolute Pressure Sensor (analog, digital) signal simulation
- Brake switch simulation
- Clutch switch simulation
- A\C request signal simulation
- A\C relay simulation
- fule pump relay simulation
- radiator fan relay simulation
- audio signal output, power amplifier drive
- steering pressure switch simulation
- fuel injection pulse width measurement
- central door lock server simulation
- anti theft resistance simulation
- Knock sensor signal simulation
- computer board working current test
- user extensional functions

3.Instrument parameters:

1. Can set the waveform output:It can set twelve channels waveform output arbitrary, can simultaneously output crankshaft 1 ° angle signal, the signal of cylinder detection, TDC of cylinder 1 signal, camshaft signal, phase precision.This machine is applied to crankshaft and camshaft signal simulation of all vehicles worldwide; also applies to the crankshaft and camshaft signal input, output simulation,and all of the automatic transmission input, output shaft signal simulation; ABS three or four

channel wheel speed signal simulation; computer set the waveform, and waveform can be long-term preservation;

- 2、 Output signals: magnetoelectric signals, hall, photoelectric signal;
- 3、 Duty cycle drive: duty cycle 1 ~ 99% continuous adjusting, frequency of 11 files regulation
- 4、 The sensor signal simulation: resistance of 100 Ω ~10000 Ω voltage 0V~5V \times 4 0V~1.5V
- 5、 Actuator drive simulation: 69 channel output simultaneously

4. Instrument application:

- 1、 Automobile sensor dynamic diagnosis, automobile engine, transmission, ABS, air conditioning, anti-theft and other computer repair, auto teaching AIDS model driven, automobile production development;
- 2、 The utility model is suitable for Germany, the United States, Japan, South Korea, and other domestic mini models etc hundreds of models;

5. Operation panel profile:

Output port:the above of the port said the abbreviation of the port name and the below is the port number (1-192) a total of 192 output ports.

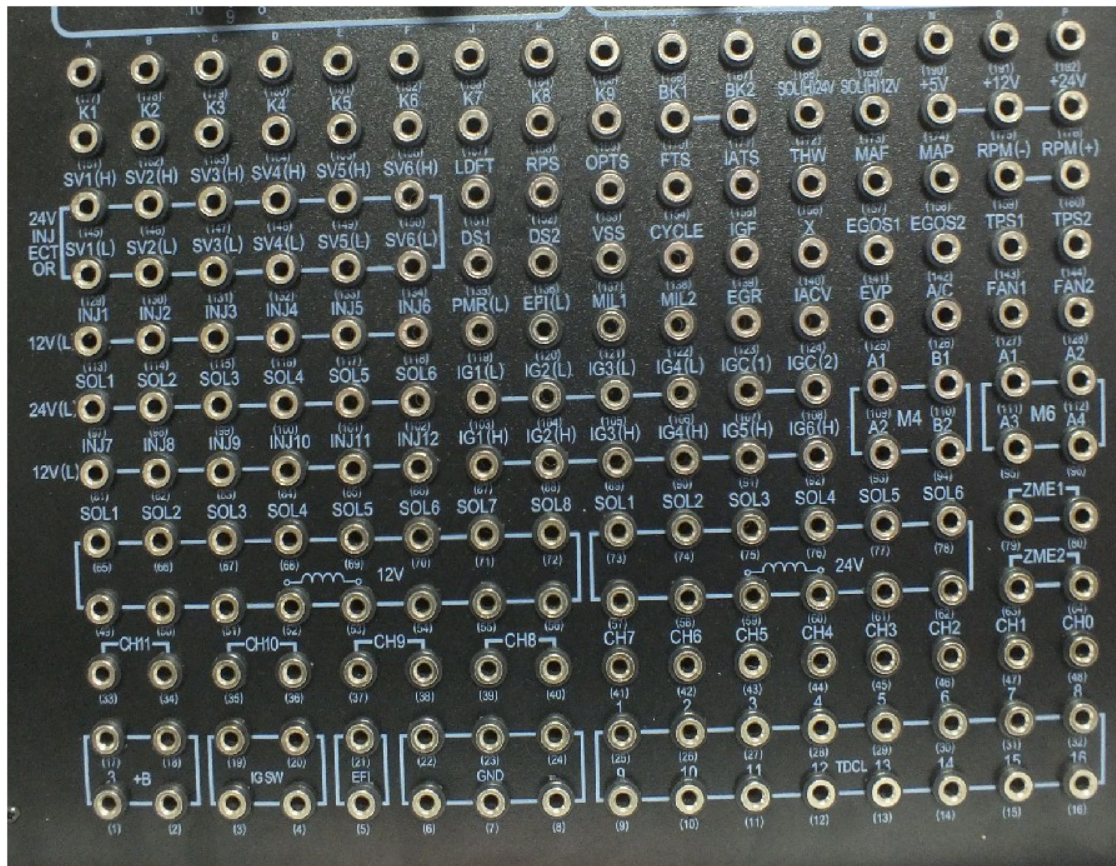

INJ1-INJ12 (port 81-86,113-118): making 1-12 cylinder injector and injection time (MS) (12V,gasoline)

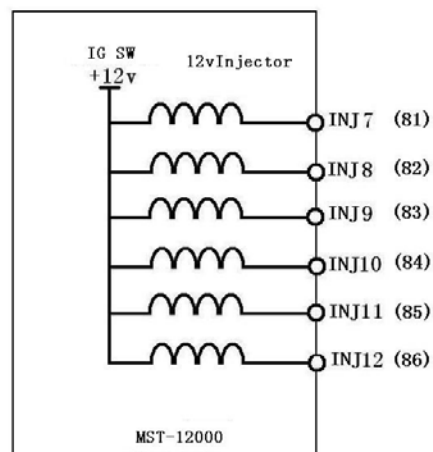
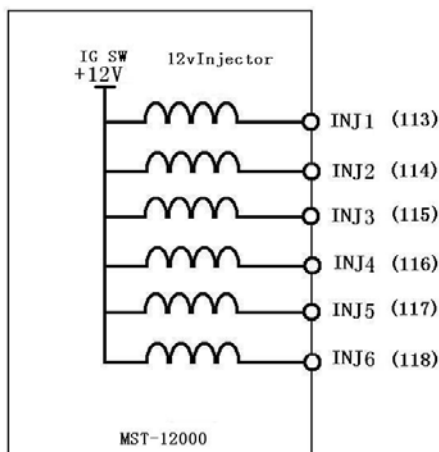

12vInjector

SV1 (H) -SV6 (H) (port 129-134), SV1 (L) -SV6 (L) (port 145-150) diesel injector signal output

(24V):

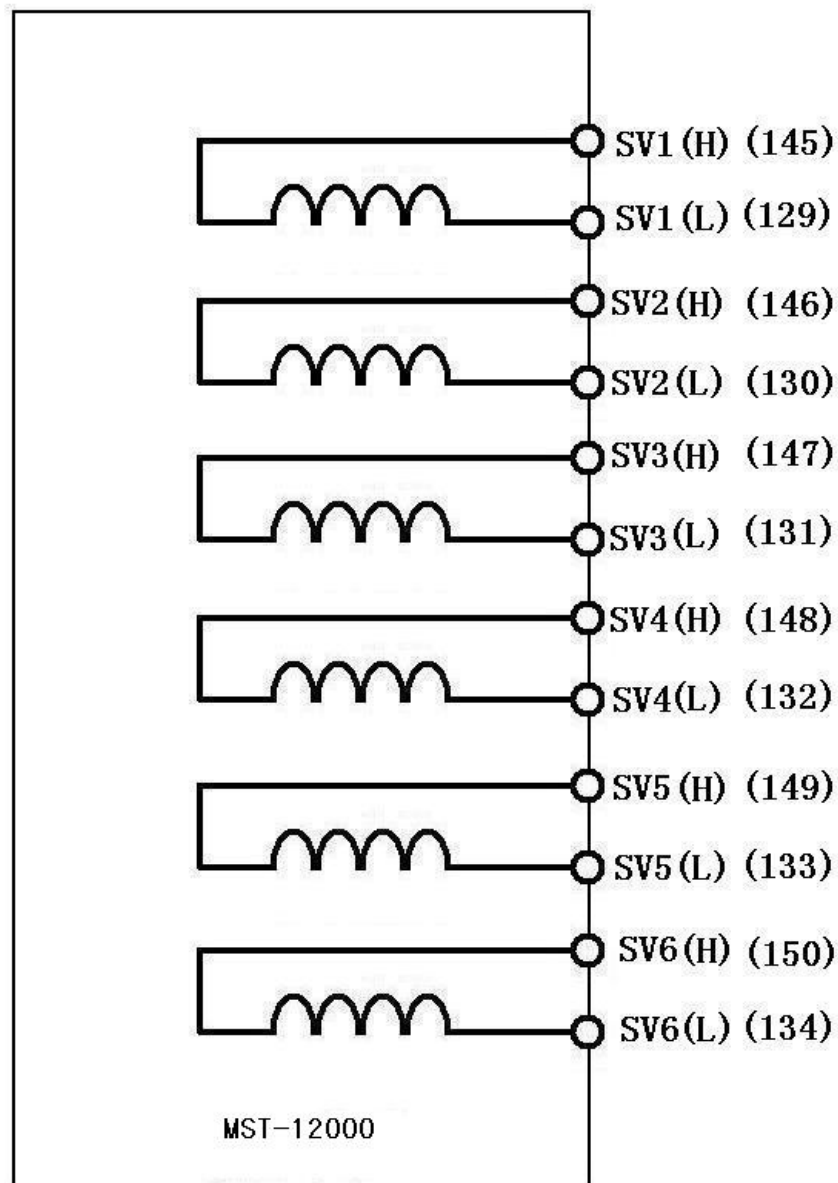

24V Iniector

Analog output:

IATS: (Port155) air charge temperature sensor 0-5V

THW: (Port156) water temperature sensor 0-5V

TPS1: (Port143) Throttle position sensor signal simulation 0-5V

TPS2: (Port144) Throttle position sensor signal simulation ratio control 0-5V , used to adjust two throttle signal output ratio. If two throttle position sensor signals need to be 2:1, then adjust TPS1 output voltage to 1v, TPS2 0.5V. And then adjust the voltage of TPS1, two signals can be 2:1.

MAP: (Port158) Air intake pressure sensor signal simulation 0-5V

MAF: (Port57) Air flow meter signal simulation 0-5V

EGOS1: (Port141) Oxygen sensor signal simulation 0-1V

EGOS2: (Port 142) Oxygen sensor signal simulation 0-1V

LDFT: (Port151) Boost pressure sensor 0-5V

RPS; (Port152) Fuel rail pressure sensor 0-5V

OPTS: (Port153) oil pressure sensor 0-5V

FTS: (Port154) oil temperature sensor

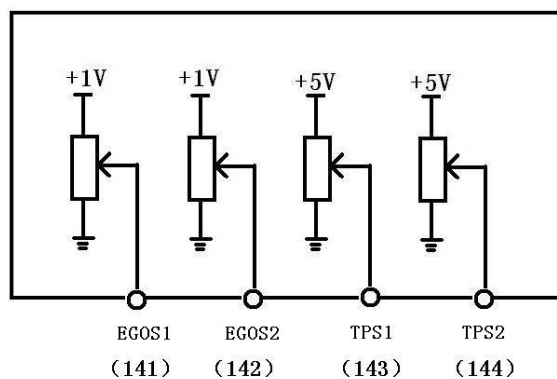
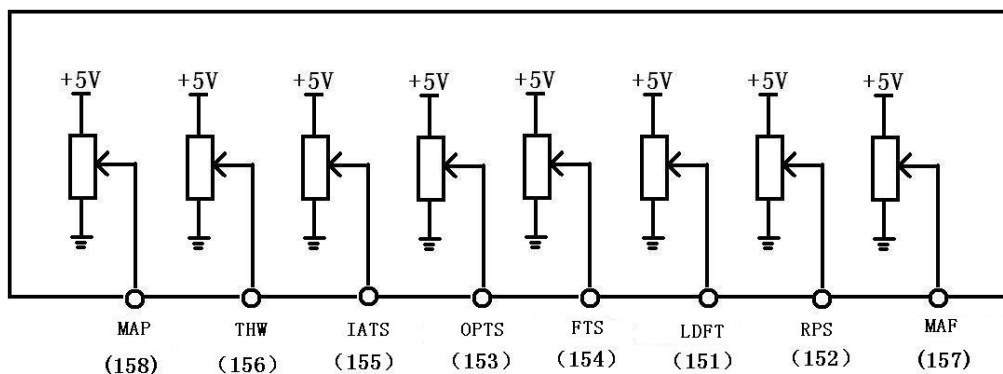

Digital signal output:

DS1: (Port135) knock sensor 1 signal simulation

DS2: (Port136) knock sensor 2 signal simulation

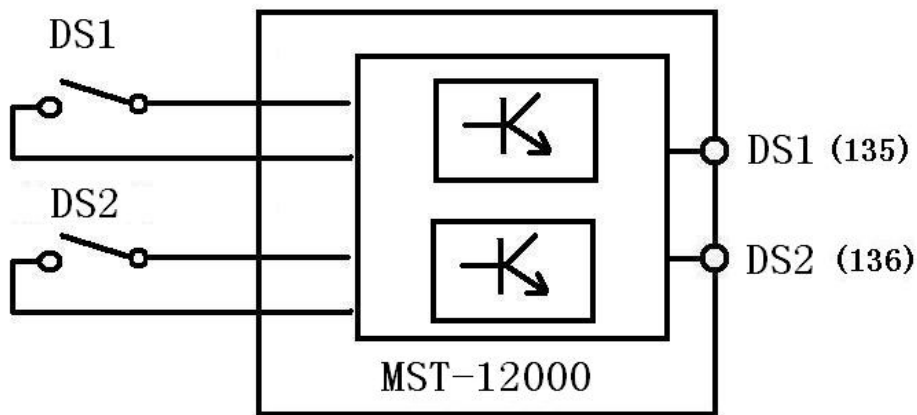

CH0-CH7: (Port41-48) The camshaft & crankshaft square wave signal
 CH8-CH11: (Port33-40) The camshaft & crankshaft ac signal (This feature requires a PC through good software calibration input signal of the crankshaft. Click on a host "OUT" knob it can be output)

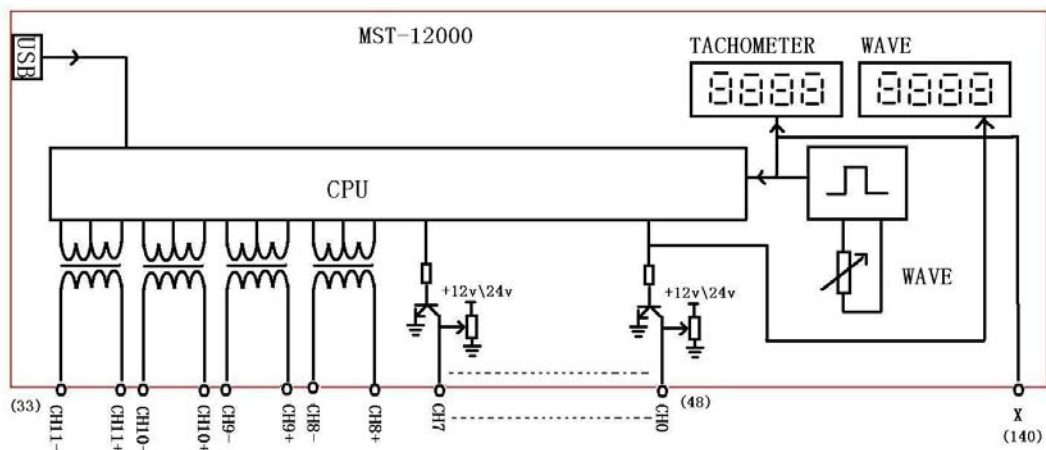

Components of simulation:

IACV: (Port140) Idle speed control valve displacement simulation

PMR: (Port135) pump relay fuel pump relay

EFI: (Port136) main relay

MIL1: (Port121)] indicator light1

MIL2: (Port122) indicator light 2

EGR: (Port123) exhaust gas recirculation

EVP: (Port125) CHARCOAL CANISTER-PURGE VALVE

A/C: (Port126) Air Conditioner Relay

FAN1: (Port127) EElectric fan relay 1

FAN2: (Port128) EElectric fan relay 2

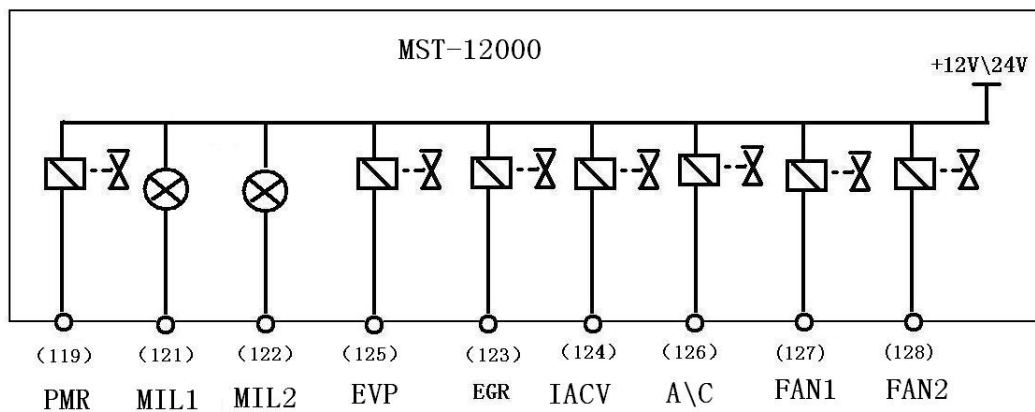

M4: (M4Port Area, Port93、94、109、110) Four wire stepper motor simulation

M6: (M6Port Area, Port95、96、111、112) Six line stepper motor simulation

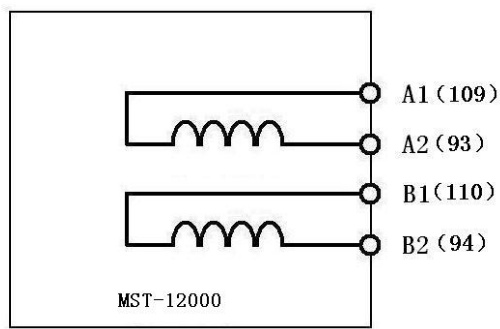

M4

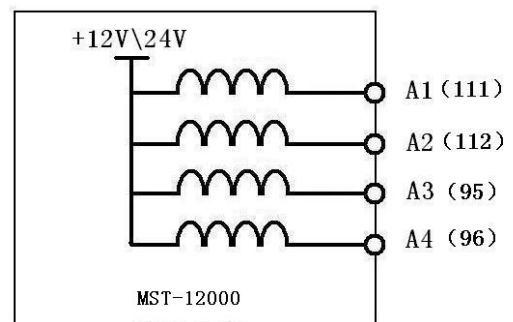

M6

ZME1: (Port79-80) Rail pressure regulator 1

ZME2: (Port63-64) Rail pressure regulator 2 (standby application)

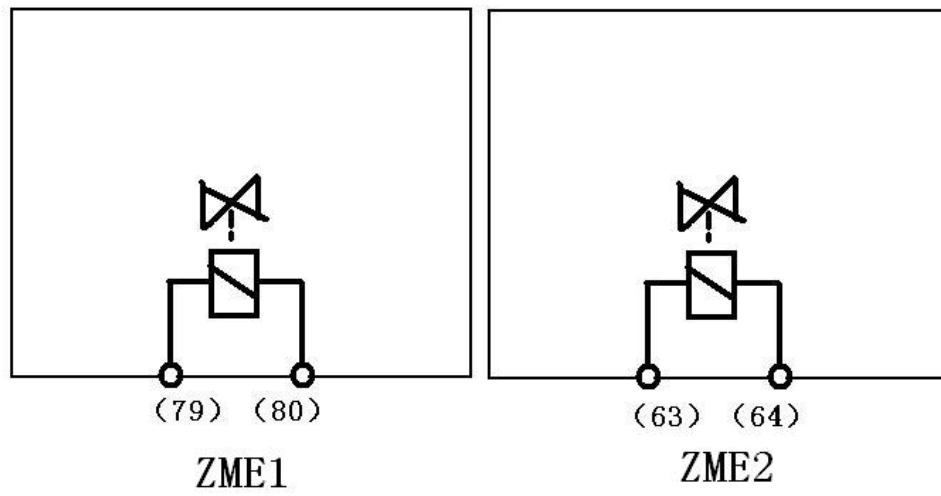

Ignition coil and ignition module simulation (B1-B6)

IG1 (L) -IG4 (L): (port 103-106) ignition coil and ignition module, indicator light negative

trigger

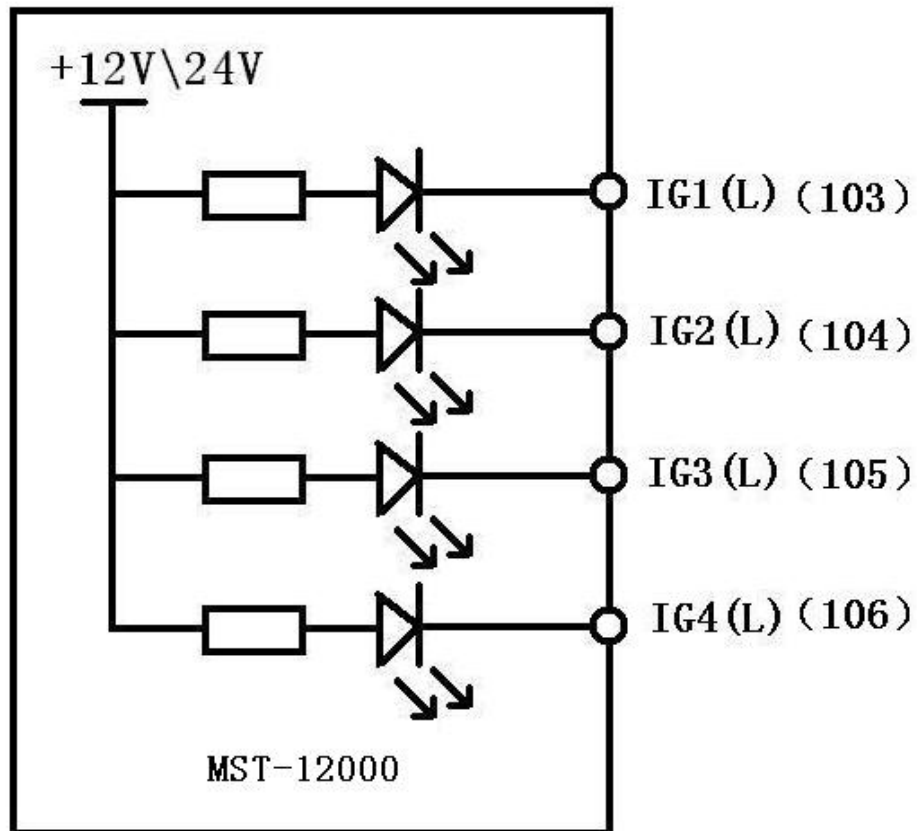

Ignition control module

IG1 (H) -IG6 (H): (port 87-92) ignition coil and ignition module, the indicating lamp is triggered

IGF (port 139) ignition feedback signals

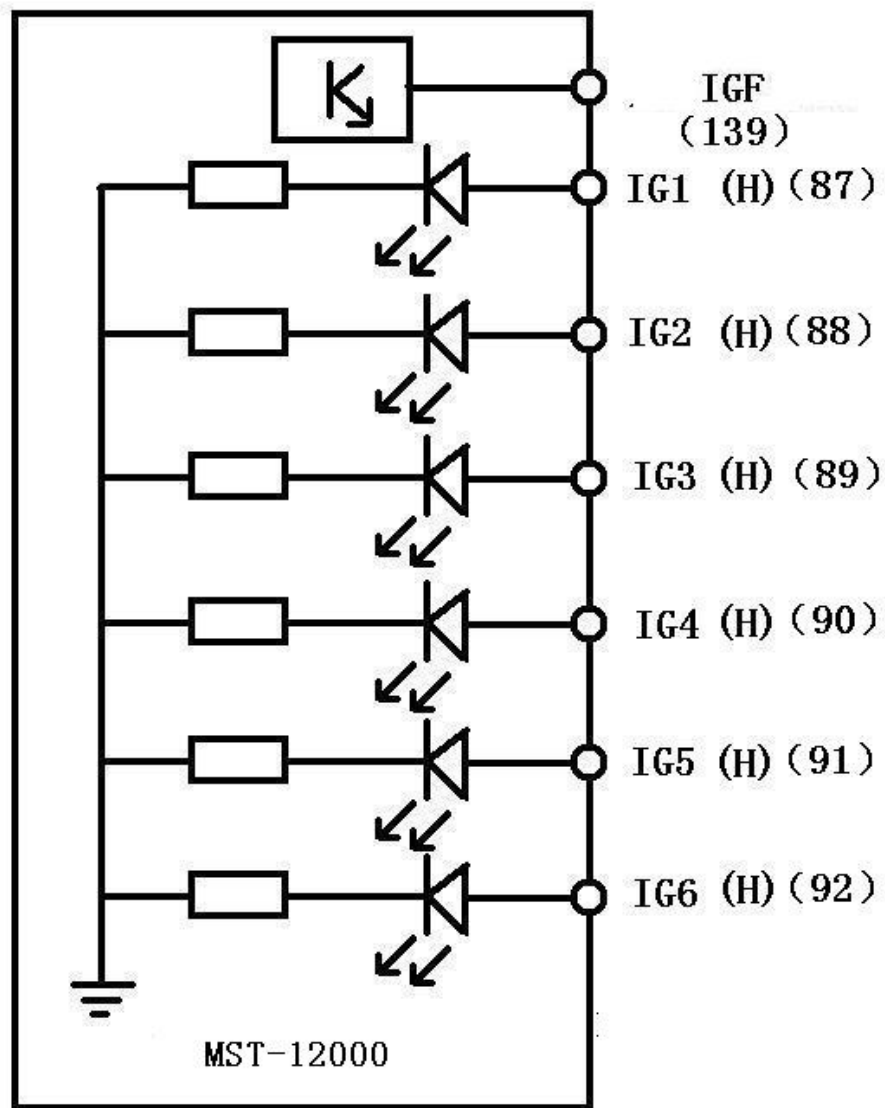

Ignition control module

IGC1, IGC2: (port -107-108) ignition coil simulation:

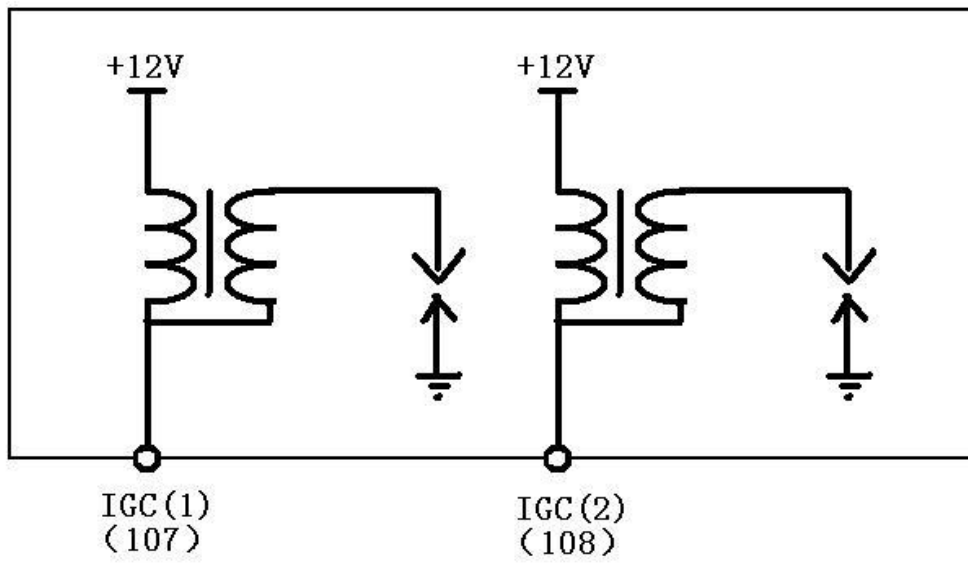

Ignitioncoil

Electromagnetic valve simulation:

SOL1 - SOL8,49 (port 65-65-56)(12V)

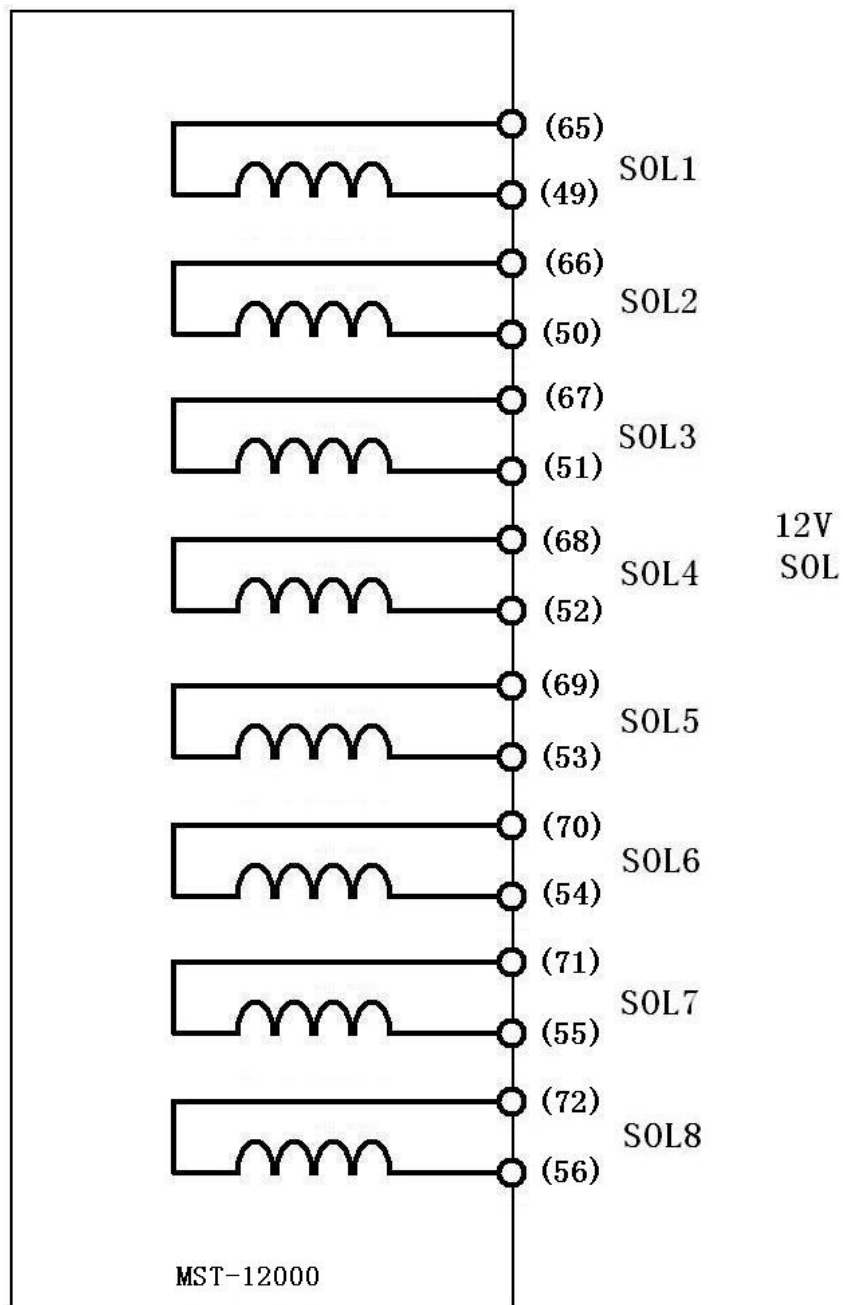

SOL1 (L) -SOL6 (L) (port 80-82,97-99) (24V)

SOL1-SOL6 (port 73-78,57-62)

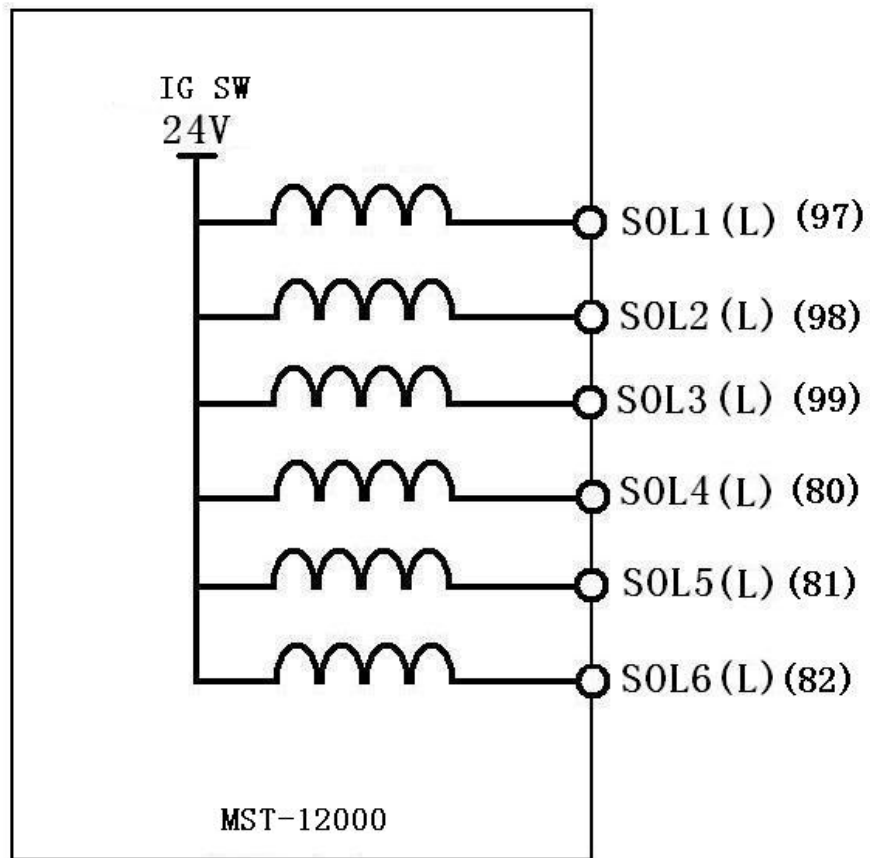

24V SOL

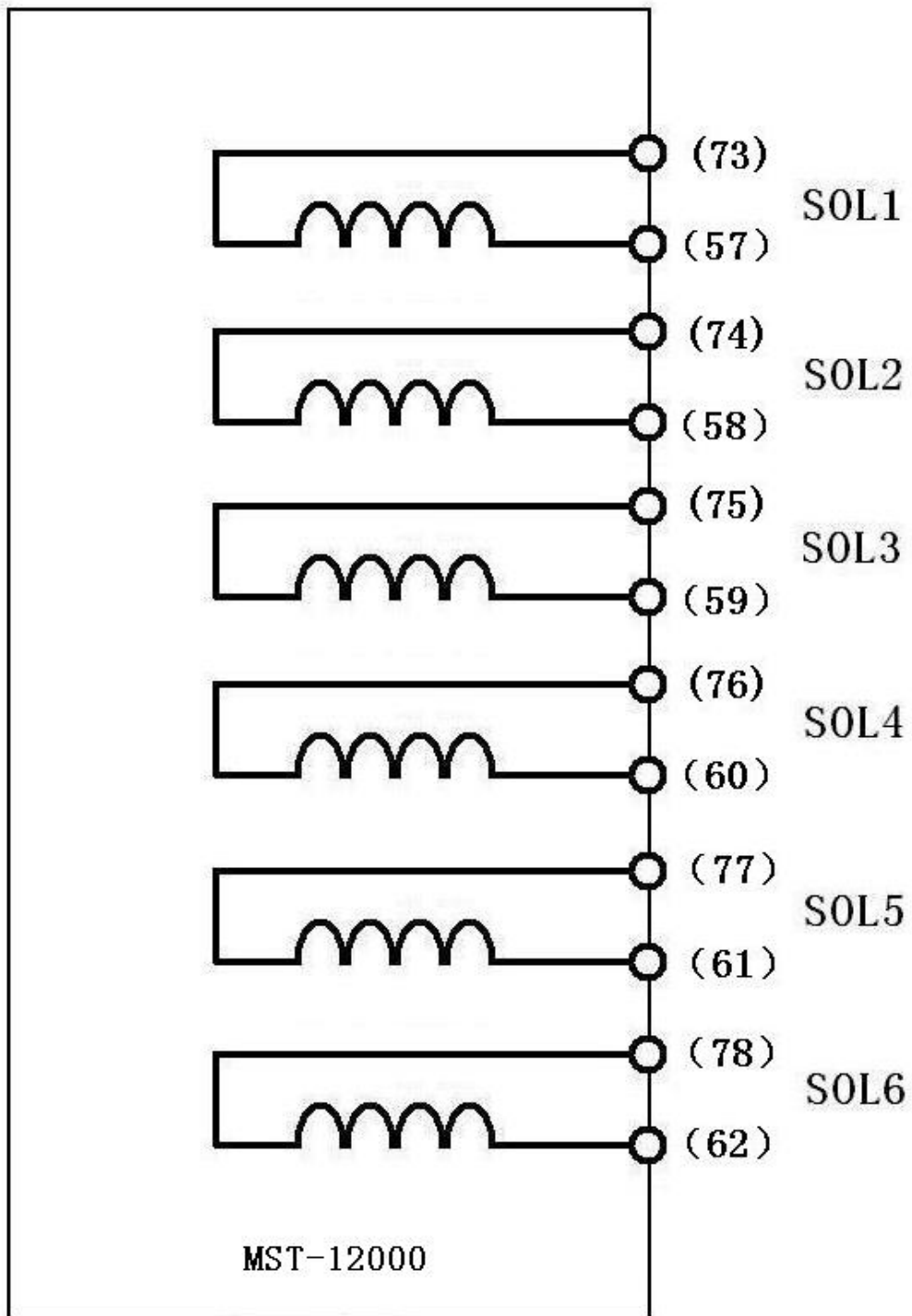

24V SOL

The power supply part:

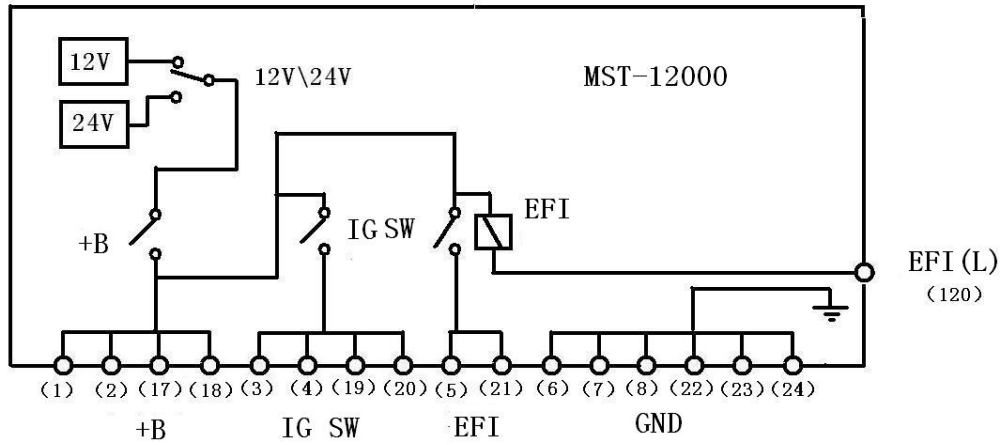

OBD diagnosis:

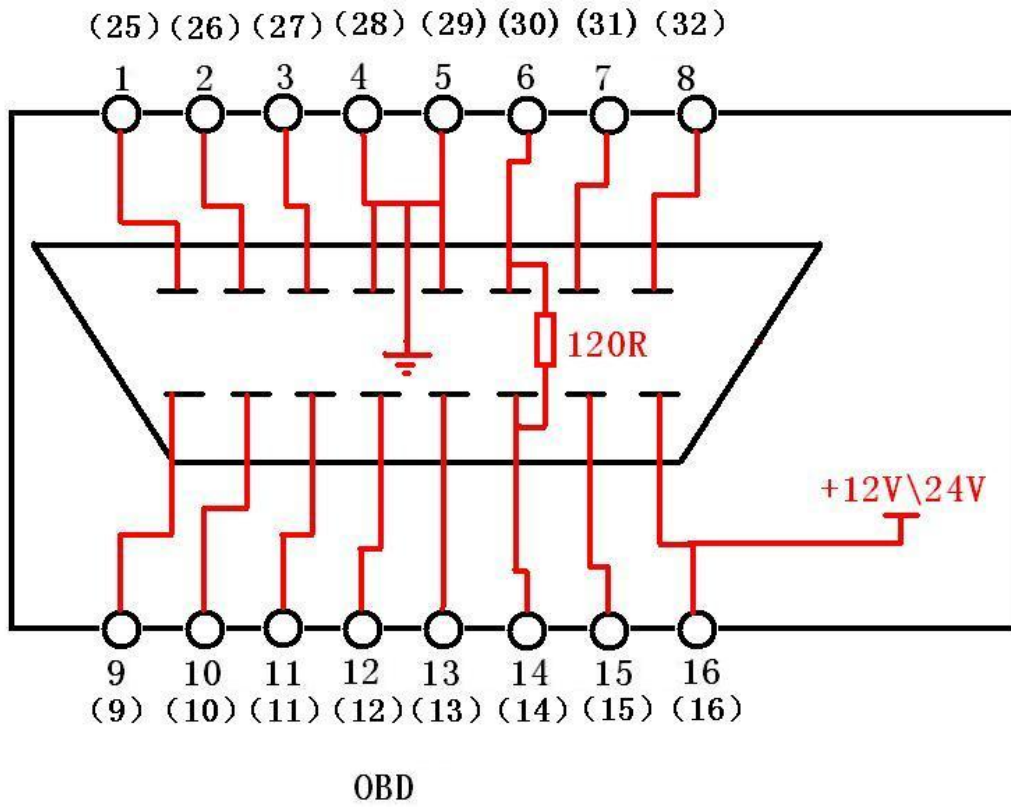

digital signals:

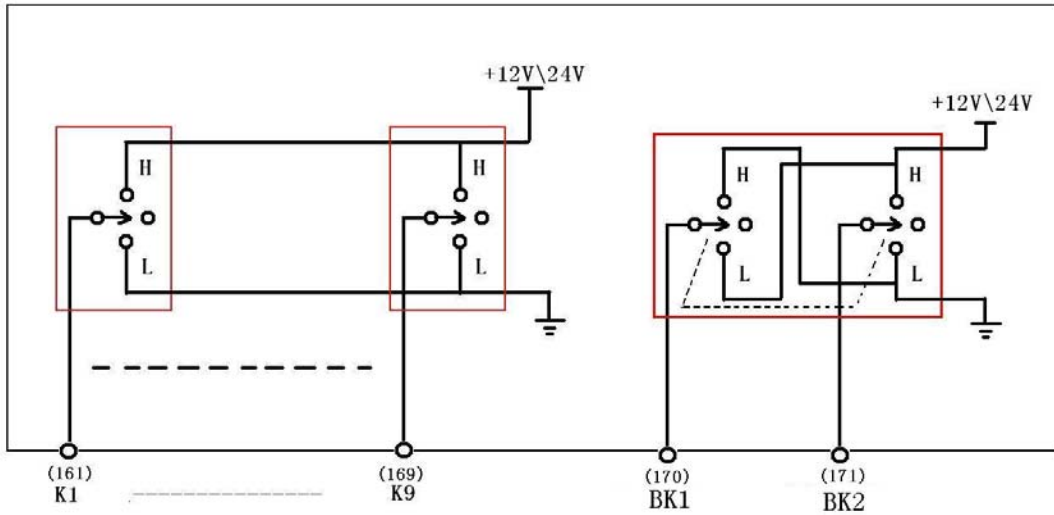

triggered relay:

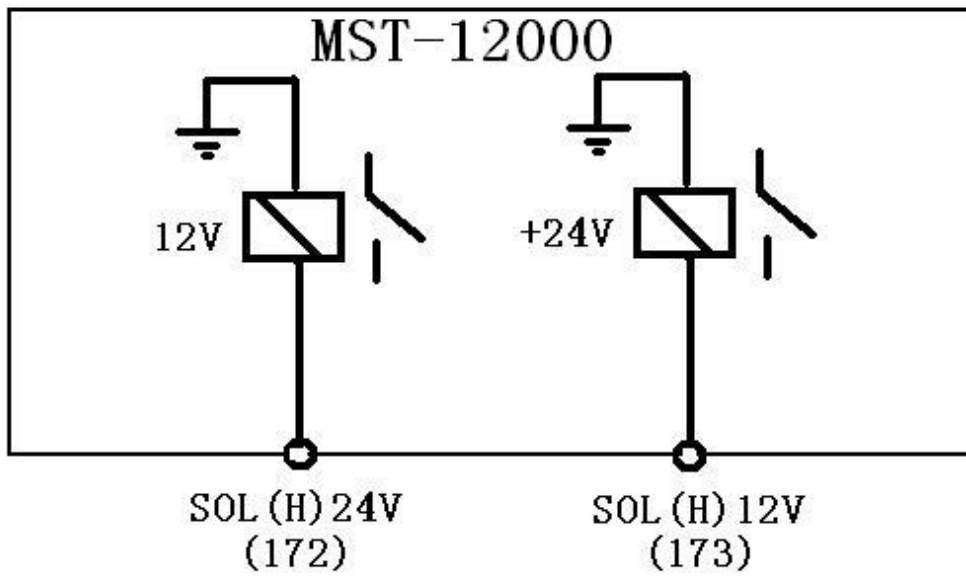

Tachometer signal:

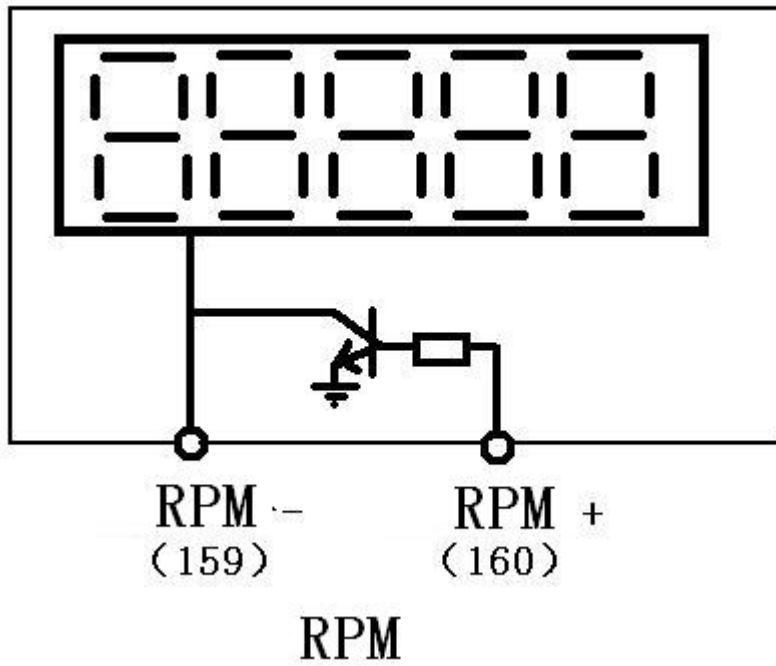

Wave setting software installation and use method:

Firstly,pls put the CD into the computer cd-rom,and open the software then copy the "simulation expert official version.Exe" file to the computer desktop and double-click the file,Double-click to open the desktop icon, the followings appear:



Click on the "signal editing", enter the signal editing interface.

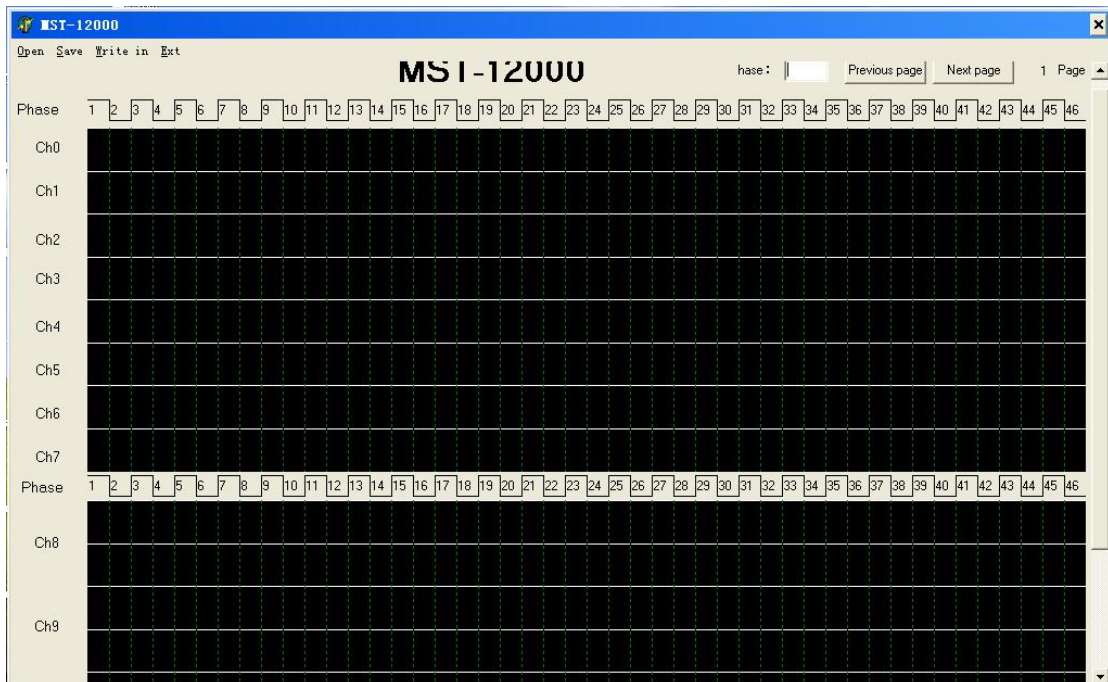

Any set zone can be setted the waveforms you need arbitrary,CH0 is the

tachometer channel, every 1 revolutions of the engine crankshaft, the channel 6 pulse.

CH1 -- CH7 is mainly used for square wave set, CH8-CH11 is mainly used for sine wave set. After the waveform set, input the waveform end position that we set the in the "hase" menu.

For example: editing a 36-2 square wave crankshaft signal in CH1, and repeat the cycle.

In the CH1 click 36 pulse continuous.

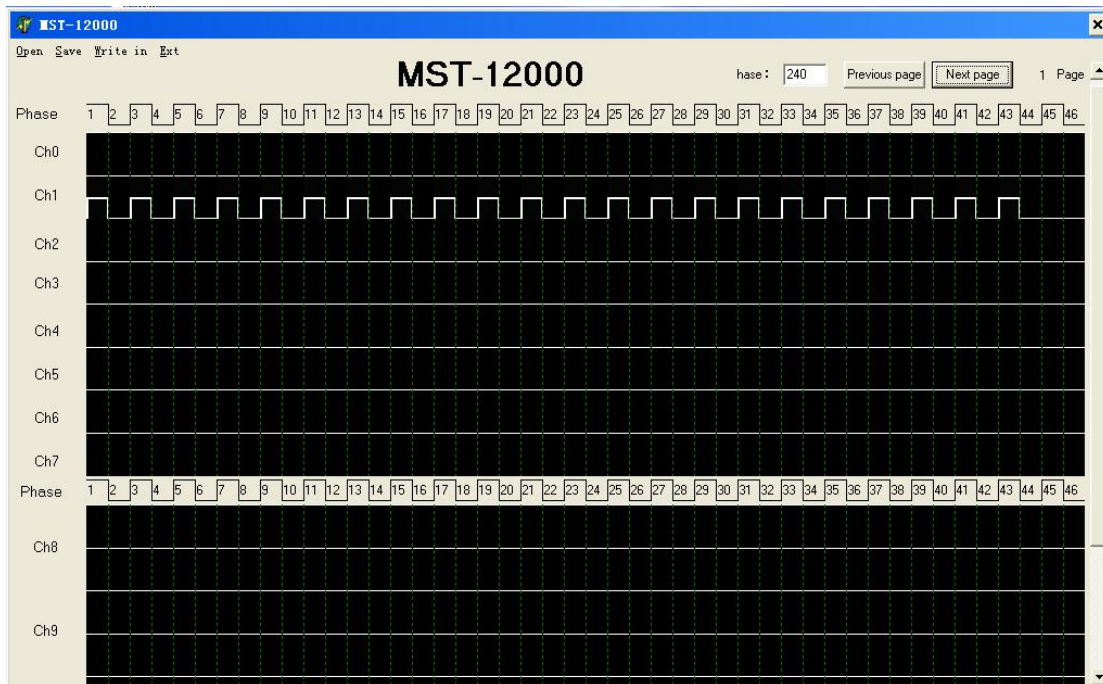

2、 In thirty-sixth pulse position as the phase 72. In the "hase" input "72"

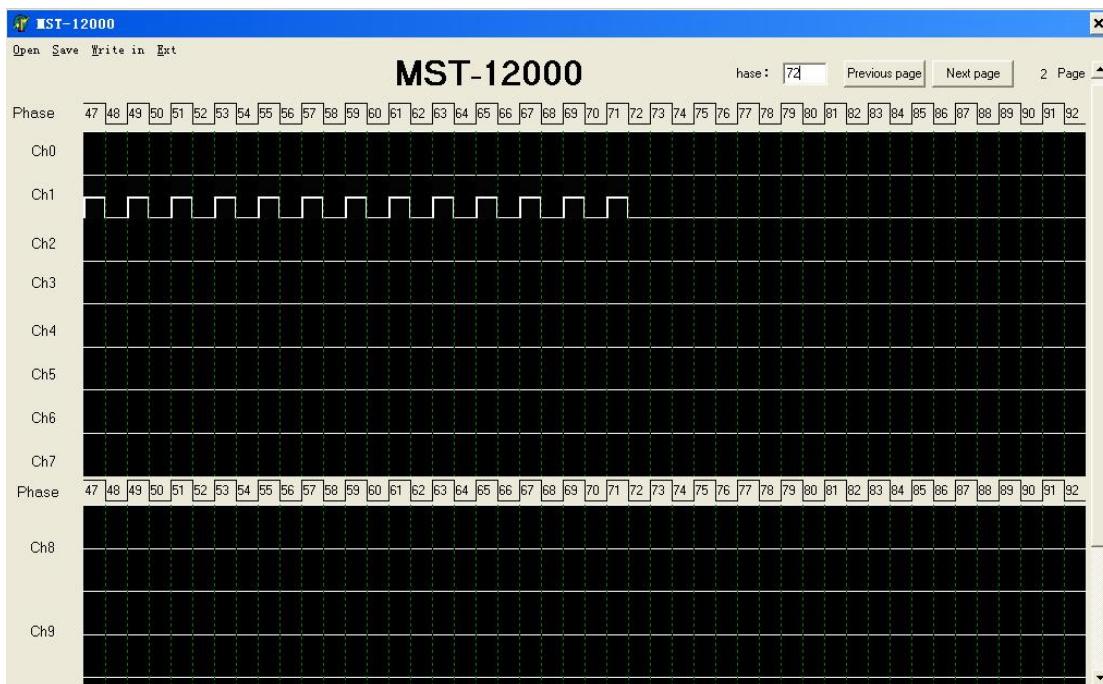

3、 Between 36 pulse,remove two pulse at random and continuously, you can get 36-2 signal.

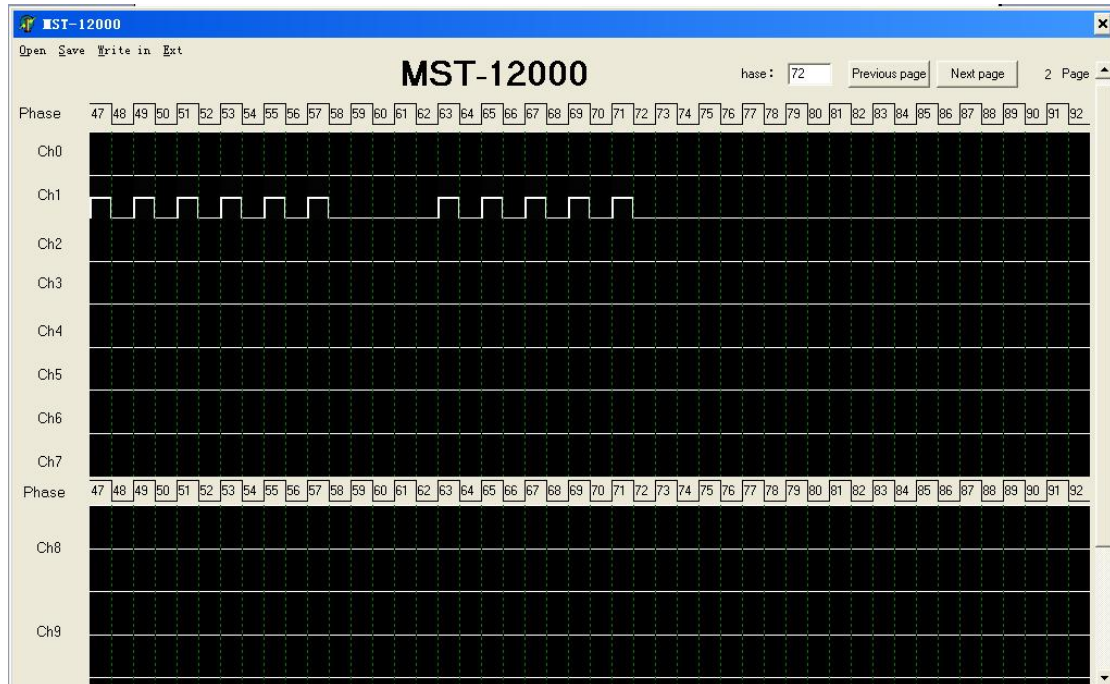

4、 With the end phase number of $72 \div 6 = 12$, that means every 12 phase then click a pulse in CH0 ,can be set to the tachometer signal.

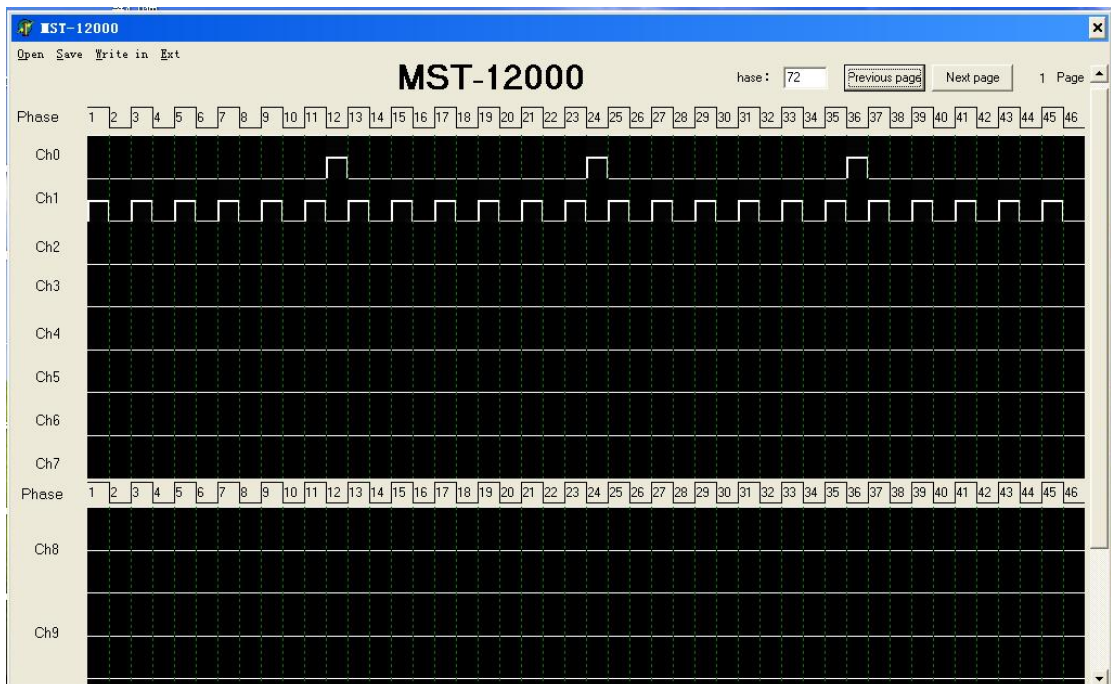

5、

6、 After the waveform settings, click "SAVE" to save the settings of the waveform.

7、 Click on the "Write in" to input the waveform into MST-12000, click "OUT" to output