

## Audi A4 RB4/ RB8

### Pin assignment at multi-pin connectors on instrument cluster

32-pin multi-pin connector, blue

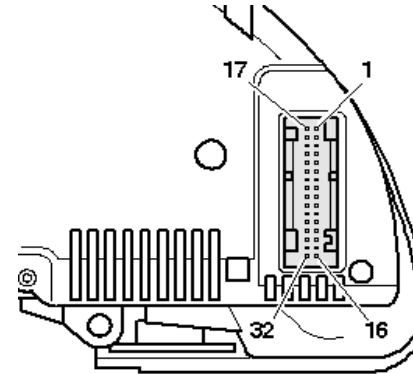

A90-0159

- |                                      |                                 |
|--------------------------------------|---------------------------------|
| 1. Washer fluid low                  | 17. Convenience CAN High        |
| 2. Coolant level low                 | 18. Convenience CAN Low         |
| 3. Fuel gauge sender                 | 19. Infotainment CAN Low        |
| 4. Coolant temperature               | 20. Infotainment CAN High       |
| 5. Control group 2 Navigation system | 21. Ambient temp. (input)       |
| 6. Control group 3 Navigation system | 22. S contact                   |
| 7. Control group x Telematics        | 23. Oil level / oil temperature |
| 8. Menu switch                       | 24. Self-levelling suspension   |
| 9. Vacant                            | 25. Menu switch (enter)         |
| 10. Bonnet switch                    | 26. Vacant                      |
| 11. Fuel gauge sender 2              | 27. Vacant                      |
| 12. Menu switch (Out A)              | 28. Menu switch (Out B)         |
| 13. Vacant                           | 29. Vacant                      |
| 14. Vacant                           | 30. Transponder 2               |
| 15. Vacant                           | 31. Transponder 1               |
| 16. FDR/TCS (= ESP)                  | 32. Terminal 31 (sensor)        |

## 32-pin multi-pin connector, green

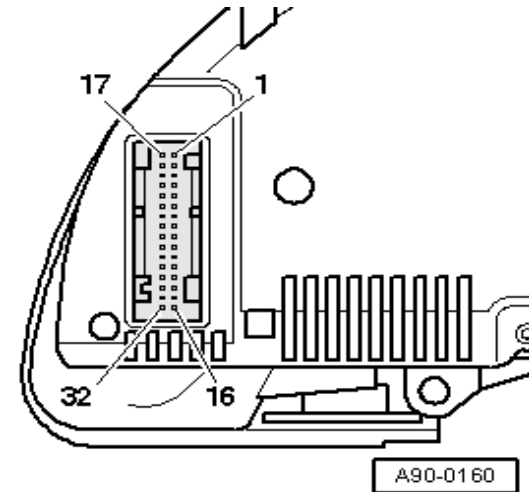

- |                                |                                   |
|--------------------------------|-----------------------------------|
| 1. Terminal 58d                | 18. Terminal 31 load              |
| 2. Terminal 30                 | 19. Terminal 31 load              |
| 3. Terminal 15                 | 20. Vacant                        |
| 4. Vacant                      | 21. Speedometer (output 1)        |
| 5. Speedometer (input)         | 22. ABS warning                   |
| 6. Speedometer (output 2)      | 23. K wire                        |
| 7. Airbag (inverted)           | 24. CAN drive (display)           |
| 8. Turn signal (right-side)    | 25. Tank flap switch              |
| 9. Brake fluid low             | 26. CAN diagnosis Low             |
| 10. Turn signal (left-side)    | 27. CAN diagnosis (display)       |
| 11. Turn signal (trailer)      | 28. CAN diagnosis High            |
| 12. CAN drive Low              | 29. HRC (headlight range control) |
| 13. CAN drive High             | 30. Belt buckle                   |
| 14. Terminal 61/charge warning | 31. External buzzer               |
| 15. Vacant                     | 32. Brake pad wear                |
| 16. Oil pressure 2             |                                   |
| 17. Terminal 58s               |                                   |